

District of Campbell River



DISTRICT OF CAMPBELL RIVER LONG TERM SEWAGE TREATMENT STUDY FINAL REPORT

Prepared for

District of Campbell River

Prepared by

Stantec Consulting Ltd.
977 Fort Street
Victoria, BC V8V 3K3

Contact: Mr. Tony Brcic, P.Eng.
Tel: 250-388-9161
Fax: 250-382-0514



Stantec

October 26, 2004

120-60131 01



Stantec

This report was prepared by Stantec Consulting Ltd. for the District of Campbell River. The material in it reflects our best judgment in light of the information available to us at the time of preparation. Any use which a third party makes of this report, or any release of, or decisions made based on it, are the responsibilities of such third parties. Stantec Consulting accepts no responsibility for damages, if any, suffered by any third party as a result of decisions made or actions based on this report.

TABLE OF CONTENTS

		Page
TABLE OF CONTENTS		I
1.0	INTRODUCTION	1
1.1	BACKGROUND	1
1.2	PROJECT OBJECTIVES	2
<hr/>		
2.0	POPULATION PROJECTION	3
2.1	GENERAL	3
2.2	NWEC WWTP SERVICE TRIBUTARY POPULATION AND SEWAGE PROJECTIONS	3
2.3	INDUSTRIAL PARK LAGOON SERVICE TRIBUTARY POPULATION AND SEWAGE PROJECTIONS	8
<hr/>		
3.0	EXISTING SYSTEMS AND FUTURE PROJECTIONS	11
3.1	GENERAL	11
3.2	NORM WOOD ENVIRONMENTAL CENTER WASTEWATER TREATMENT PLANT (NWEC WWTP)	11
	3.2.1 Current Condition	11
	3.2.2 Future Projection	20
3.3	INDUSTRIAL PARK LAGOON (IPL)	25
	3.3.1 Current Condition	25
	3.3.2 Future Projection	29
<hr/>		
4.0	SYSTEM UPGRADE OPTIONS AND COST ESTIMATES	32
4.1	GENERAL	32
4.2	NORM WOOD ENVIRONMENTAL CENTER WASTEWATER TREATMENT PLANT (NWEC)	32
4.3	INDUSTRIAL PARK LAGOON (IPL)	41
<hr/>		
5.0	OPERATIONAL BENCH MARKING	45
6.0	CONCLUSION AND RECOMMENDATIONS	47
6.1	NORM WOOD ENVIRONMENTAL CENTER (NWEC WWTP)	47
6.2	INDUSTRIAL PARK LAGOON (IPL)	50

APPENDICES:

APPENDIX A CONCEPTUAL LAYOUT OF NVEC WWTP PHASE II OPTION 1

APPENDIX B CONCEPTUAL LAYOUT OF NVEC WWPT PHASE II OPTION 2

APPENDIX C COST ESTIMATES

**APPENDIX D NORM WOOD ENVIRONMENTAL CENTER SEWAGE
TREATMENT PLANT CATCHMENT AREA**

APPENDIX E INDUSTRIAL PARK LAGOON SEWER CATCHMENT AREA

1.0 INTRODUCTION

The District of Campbell River (DCR) community is facing an orderly growth of population and industrial development with prosperity. The District is engaged in developing a long-term sewage treatment strategy to accommodate future regional demands. Stantec Consulting Ltd. is retained to conduct a comprehensive study on the two regional treatment facilities (the Norm Wood Environmental Centre Wastewater Treatment Plant (NVEC WWTP) and Industrial Park Lagoon (IPL)) to evaluate their system performance and capacities. Based on system evaluation and future scenario projections, operational improvement and facility upgrades are recommended for system optimization and future needs. Retrofit options are also provided in assisting the District's long-term sewage treatment strategy development.

1.1 BACKGROUND

Commenced in June 1996, the NVEC WWTP is a secondary treatment facility with 52,000 population-equivalent (PE) design capacity (Design Stage 1b, Dayton & Knight, 1997) to serve the District of Campbell River, the North Campbell River and Quinsam areas. The treatment plant receives the sewage collected within these areas, mainly the domestic and institutional sources, and discharges the treated effluent to Discovery Passage.

The unit treatment processes include a mechanical bar screen to remove coarse solids and debris, two oxidation ditches to biologically remove organic matters, followed by two secondary clarifiers to settle solids and biomass generated in the biological process. The biosolids collected from the bottom of clarifiers is stabilized in an aerobic digester for volatile solids (VS) destruction and pathogen reduction. Supernatant from the digester is returned to the oxidation ditch for further treatment, and the stabilized biosolids are then transferred to a storage basin for further solids thickening. The thickened biosolids are arranged for silviculture land application on an adjacent lot south of the plant. Currently, only one oxidation ditch is online in service alternately due to low influent flow and loads. The treated effluent quality is generally in compliance with the criteria specified in the existing discharge standards (5-days biochemical oxygen demand \leq 45 mg/L, total suspended solids \leq 45 mg/L, PE 14625).

The IPL is located approximately 3.5 km north of the NVEC WWTP along the Highway 19. The existing facility consists of an un-aerated single-cell facultative lagoon with surface area approximately 2,500 m². The IPL is originally designated and constructed in 1982 to treat the sewage and wastewater generated from the industrial park. The most recent upgrade was completed in 1998 by installing a new geo-textile liner.

Records showed that the waste stream generated from the adjacent Renewable Resources Composting site may have caused significant impacts to the lagoon

operation. High flow and loads from the composting site and the stormwater have frequently caused the non-compliance of effluent quality in recent years. A source control program and system improvements to enhance the treatment efficiency and capacity are on the District's prior agenda. Future expansion of treatment capacity is also necessary to accommodate the industrial and residential development in this area.

1.2 PROJECT OBJECTIVES

The objective of this assignment is to evaluate the treatment system performance for each WWTP and their capacities for the system optimization and future demands. Results and recommendation will support the development of a comprehensive long-term sewage treatment strategy for the District. The major tasks include the following:

- Review the plant historical data and assess the existing system performance
- Assess the future population and wastewater loading projections
- Conduct the treatment process model simulations in supporting the future system retrofit and upgrade decisions
- Operational cost benchmarking
- Provide system retrofit options and cost estimates
- Develop the long-term sewage treatment strategy for the District.

2.0 POPULATION PROJECTION

2.1 GENERAL

The regional population growth is significantly affected by the community development and economic activity. The regional sewage treatment capacity needs to meet the future demands on a timely and cost-effective basis. Based on the regional population growth forecasts within the NWECC WWTP and IPL service tributaries, the future demand of treatment capacity can be effectively planned and supplied.

2.2 NWECC WWTP SERVICE TRIBUTARY POPULATION AND SEWAGE PROJECTIONS

The District experienced rapid population growth during the 70's and 80's. The population growth lingered in late 90's and leveled off afterwards. A general area plan of the NWECC catchment area is shown in Appendix D. The population records (1998 to 2002) within the sewer service tributaries, including the District of Campbell River (DCR), the Campbell River First Nation, and the Quinsam First Nation are summarized in Table 2.1. Area "D" of the Comox-Strathcona (formerly Area "D" of the South Campbell River") and the industrial properties east of Highway 19 are not included in this study.

The population growth ceased from 1998 to 2000, and a significant decrease in population occurred in 2001. In the same period of time, the Campbell River First Nation had grown at a rate approximately 10% in the past five years. The total population of the year 2002 in the DCR is about 30,900, which is 3% less than the population in 1998.

TABLE 2.1: POPULATION RECORDS (1998-2002)

Year	District of Campbell River	Campbell River Reserve	Quinsam Reserve	Total Contributing Population	Population Change
1998	31,362	551	-	31,913	
1999	31,286	565	-	31,851	-62
2000	31,253	580	142	31,975	124
2001	29,700	595	-	30,295	-1680
2002	30,443	611	150	31,204	908

Future population growth could be significantly affected by regional business developments and employment opportunities. The future growth needs to be considered to assure adequate sewage treatment capacity within the service areas. The District's Official Community Plan (OCP, 1997) has adopted a growth management policy to retain residential development within the urban containment

area. High development activity can be expected in the south of the DCR, the North Campbell River along the Island Highway, and the Quinsam Height area. Meanwhile, the prime future community development will be extended longitudinally to the north and south, which may increase the difficulty and cost for expanding the sewage collection infrastructure. The District's OCP adopted a growth rate for the next two decades between 1.64% to 3.0% (OCP, 1997). The District's Liquid Waste Management Plan (LWMP) Stage II (1991) also applied a growth rate between 2.5% to 3.5% for the design of sewage treatment capacity.

In a recent forecast by the District's Community Service Planning Department, a 1.5 % growth rate was recommended for the District over the next twenty years. A 2.6% growth rate for the Campbell River First Nation and an increase of 6 persons per year for the Quinsam First Nation and the Homalco First Nation are considered in these areas. Three growth scenarios, high growth rate at 3.5% (LWMP II, 1991), medium growth rate at 2.5% (OCP, 1997) and low growth rate at 1.5% (DCR Planning Department, 2002) are projected in Figure 2.1. The DCR's maximum build-out population, based on designations in the 1997 OCP, is estimated to be approximately 65,000 people. According to the population projections, the population growth will not exceed the maximum build-out in the region within the next two decades (see Figure 2.1).

FIGURE 2.1: POPULATION PROJECTIONS (20 Years)

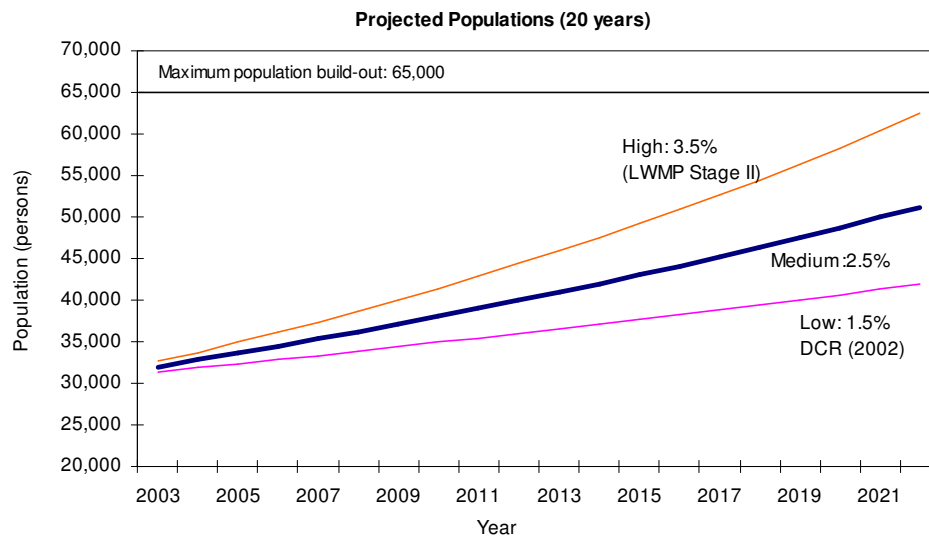

The projected population by 2023 at the low (1.5%), medium (2.5%), and high (3.5%) growth rate scenarios are approximately 42,500, 52,500, and 64,600, respectively. The population projections for the next forty years are also summarized in Table 2.2, with three different growth scenarios. In early 2003, the District has selected an annual population growth rate of 2.5 % increase for the

regional planning purpose. At this 2.5% growth scenario, the population in the region will reach 65,000 persons by 2030.

TABLE 2.2: POPULATION PROJECTIONS (40 Years)

Year	Population Growth Rate		
	Low	Medium	High
	1.5%	2.5%	3.5%
2001	30,300	30,300	30,300
2003	31,400	32,000	32,600
2008	33,900	36,200	38,700
2013	36,500	41,000	45,900
2018	39,400	46,400	54,500
2023	42,500	52,500	64,600
2028	45,900	59,300	76,700
2033	49,500	67,100	91,000
2038	53,400	76,000	108,000
2043	57,700	85,900	128,100

The sewage flow and load (data collected by the NWECC WWTP during 1998 to 2001) are summarized in Table 2.3 and Table 2.4, respectively. The sewage production per person during the dry weather flow (ADWF) seasons averaged about 406 L/cap./d (107 gal/cap./d), which is considered normal with all the contributions of residential, commercial and institutional (C&I) in the sewer catchment. The ratio of the annual average flow (AAF) to the ADWF is about 1.1. The ratios of the maximum monthly average flow (MMF) to the ADWF, and the peak daily flow (PDF) to the ADWF, are about 1.6 and 2.4 respectively. These flow factors are at the high end of typical ranges, therefore, significant influences of inflow and infiltration (I/I) are possible. Additional information is required to determine the degree of I/I impacts (e.g. instantaneous flow rate and sewer network conditions etc.)

TABLE 2.3: SEWAGE FLOW PRODUCTION PER PERSON

Year	Population	Average Dry Day (ADWF)		Max Month (MMF)		Peak Day (PDF)	
		(m ³ /d)	(L/cap/d)	(m ³ /d)	(L/cap/d)	(m ³ /d)	(L/cap/d)
1998	31,913	12,525	392	18,315	574	24,949	782
1999	31,851	12,872	404	20,118	632	29,560	928
2000	31,975	12,451	389	16,401	513	26,645	833
2001	30,295	13,255	438	20,306	670	29,748	982
		Average	406	Maximum	670	Maximum	982

Accordingly, the annual averages of BOD and TSS loads per person are approximately 0.068 kg/cap./d (0.15 lb/cap./d) and 0.074 kg/cap./d (0.16 lb/cap./d). The maximum monthly average BOD and TSS loads are about 0.102 kg/cap./d (0.22 lb/cap./d) and 0.118 kg/cap./d (0.26 lb/cap./d), respectively. Since these maximum monthly average loads were observed during the dry weather months (May to September), the organic and solids loading contributions of I/I are considered unlikely.

TABLE 2.4: SEWAGE LOAD PRODUCTIONS (BOD and TSS) PER PERSON

Year	Population	BOD				TSS			
		Average		Max Month		Average		Max Month	
		(kg/d)	(kg/cap/d)	(kg/d)	(kg/cap/d)	(kg/d)	(kg/cap/d)	(kg/d)	(kg/cap/d)
1998	31,913	1996	0.063	2429	0.076	2086	0.065	2525	0.079
1999	31,851	2351	0.074	3245	0.102	2401	0.075	3495	0.110
2000	31,975	2237	0.070	2921	0.091	2509	0.078	3777	0.118
2001	30,295	1988	0.066	2312	0.076	2344	0.077	2680	0.088
		Average	0.068	Maximum	0.102	Average	0.074	Maximum	0.118

The maximum month flow and load conditions are critical in the biological treatment system (e.g. oxidation ditch process). Future sewage flow projections at maximum monthly average flow (MMF) for the three growth scenarios (1.5%, 2.5% and 3.5% of population growth) are illustrated in Figure 2.2. The NVEC WWTP design maximum monthly flow of Stage 1b (52,000 PE) growth scenario is currently 33,100 m³/d (Dayton & Knight, 1997).

The maximum monthly average BOD and TSS loads are projected in Figure 2.3 and Figure 2.4, respectively. The NVEC system design load capacities of BOD load (5,210 kg/d) and TSS load (4,740 kg/d) are also illustrated. The intersections of projections and design criteria (flow and loads in Figure 2.2, 2.3, and 2.4) suggest the remaining system capacity. The design and actual system capacity issues are discussed in the following Section 3.

FIGURE 2.2: MAXIMUM MONTHLY AVERAGE SEWAGE FLOW PROJECTIONS

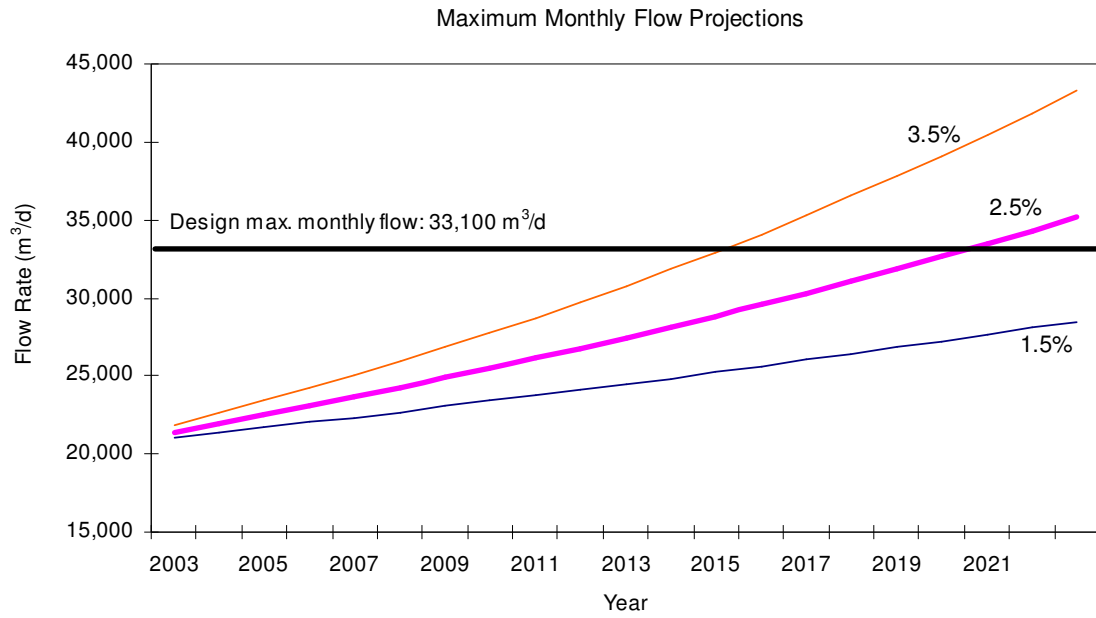

FIGURE 2.3: MAXIMUM MONTHLY AVERAGE BOD LOAD PROJECTIONS

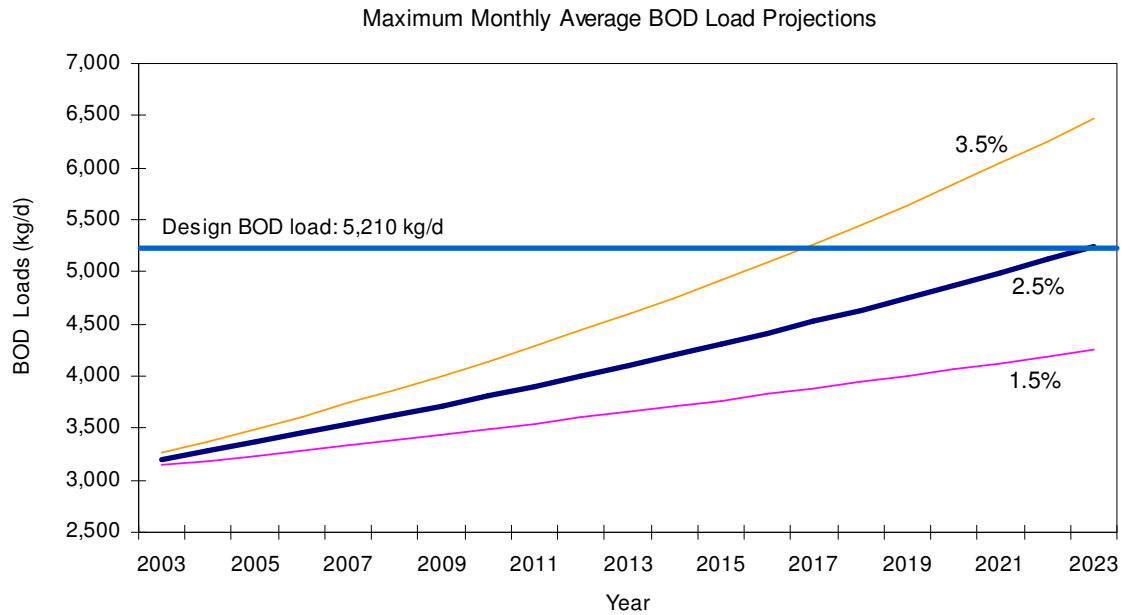
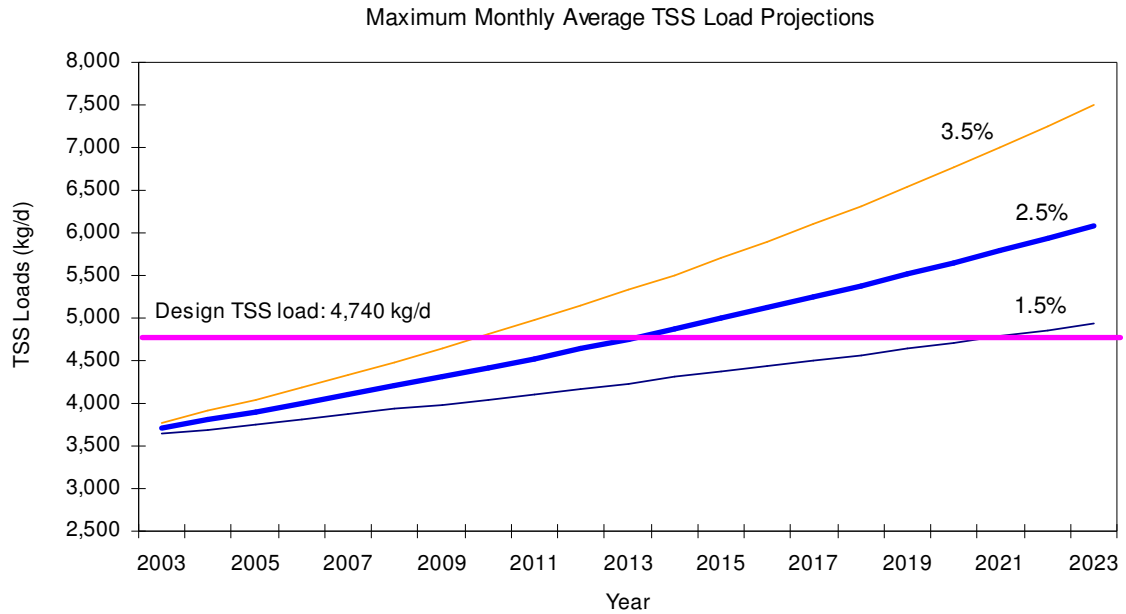

FIGURE 2.4: MAXIMUM MONTHLY AVERAGE TSS LOAD PROJECTIONS



2.3 INDUSTRIAL PARK LAGOON SERVICE TRIBUTARY POPULATION AND SEWAGE PROJECTIONS

The Industrial Park Lagoon (IPL) was originally designated to treat light wastewater generated from the Industrial Park. In recent years, high organic and hydraulic loads entering the lagoon system has resulted in significant impacts to the treatment system and caused numerous compliance violations of the effluent quality. The plant data have revealed that heavy organic and solids loads coming from the Renewable Resources composting facility, and the hydraulic load during the wet weather and storm events, have exceeded the original design capacity. With the disconnection of the compost effluent stream in 2002, the lagoon system appears to be recovering.

The current tributary for the IPL service area includes the Phase I and Phase II Industrial Parks, approximately 44 hectares industrial zoned lots. A general area plan of the IPL catchment area is shown in Appendix E. Residential units along the Duncan Bay Road and Gordon Road (currently using individual septic system), future residential development lots (Plan 34490, Lot A, D.L. 30, Land District 51) and nearby residential development are not included in the current sewer service plan. It requires substantial boundary expansion to extend the sewage collection service. Therefore, the industrial park wastewater is planned as the prime demand, plus possible residential sewage connection as the IPL service area build-out capacity.

The wastewater production from industrial activity is highly dependent on the occupancy and practice activities. The wastewater generated from the industrial park may vary from low strength office washrooms to high strength process waste (e.g. fish processing and fish net cleaning). However, seasonal plant operations and instantaneous discharge are not closely monitored within the area. Therefore, it is difficult to precisely estimate the wastewater flow and characteristic without a complete apportion study and monitoring program.

Based on the historical data reviews (1999 to 2002), a baseline of flows and loads was established from the dry weather conditions. These baseline flow and loads, without considering the contribution of surface runoff, are used to estimate the service area build-out capacity. The total population-equivalent (PE) for the Industrial Park Phase I and Phase II sewage flow and loads is about 80 PE. The residential units are estimated approximately 300 persons (in October 2002 and January 2003). This existing residential PE includes the existing households and projected subdivision development (assuming 2.5 person/household, 70 detachment households in total). The overall tributary build-out including the Industrial Park and potential residential sewage connections are summarized in Table 2.5. The total area build-out is approximately 220 m³/d, with a BOD of 42 kg/s and a TSS of 36 kg/d.

The projection of future demand of the Industrial Park tributary is highly dependent on the occupancy and development activity. The source control program is also crucial to the success of the lagoon operation. The discharge from the industrial operations with high organic and solids loads, such as the fish processing and composting practice, apparently play a significant role in the future demand planning and should be avoided. The effluent from the composting facility currently bypasses the IPL. DCR is continuing a monitoring program to ensure the Renewable Resources effluent is limited to domestic flows only.

**TABLE 2.5: INDUSTRIAL PARK LAGOON SERVICE TRIBUTARY
BUILD-OUT OF FLOW AND LOADS**

	Industrial Park Rate*	Industrial Park Build-out	Residential Rate**	Residential Build-out	Total Tributary Build-out
Area or PE	-	44 Hectares	-	300 PE	
Flow	1.82 m ³ /d/hect	80 m ³ /d	0.45 m ³ /d/PE	135 m ³ /d	220 m ³ /d
BOD	0.218 kg/d/hect.	10 kg/d	0.107 kg/d/PE	32 kg/d	42 kg/d
TSS	0.182 kg/d/hect.	8 kg/d	0.091 kg/d/PE	28 kg/d	36 kg/d

*: based on historical data (1999 to 2002 dry weather)

** : based on LWMP Stage II (1991).

It is considered unrealistic to make any timely growth projections with limited information of future development in the area. However, several upgrade options can be considered to accommodate various development scenarios with demands, including upgrading the IPL plant, construct a new regional treatment plant, or pumping the sewage to the NVEC WWTP for treatment. Therefore, rather than projecting the timely future growth, the system capacity of each upgrade option will be discussed in the following sections.

3.0 EXISTING SYSTEMS AND FUTURE PROJECTIONS

3.1 GENERAL

The sewage influent loads, plant operational conditions, and unit process performance of the NVEC WWTP are evaluated jointly to examine the system capacity. Computer process model simulations were conducted to investigate the operating scenarios and system capacities. This evaluation is based on the current permit effluent standards as the minimum requirement of BOD below 45 mg/L and TSS below 45 mg/L. The treatment capacity of the IPL system was also evaluated using the process model and empirical equations. The target effluent qualities of the IPL system are 45 mg/L of BOD and 60 mg/L of TSS. It should be noted that these capacity projections will be subject to new legislative and regulatory mandates that come to affect, e.g. more strict effluent quality requirements.

Computer process modeling was conducted to simulate future scenarios and estimate the system capacity. Several working models were developed using the EnviroSim® Biowin32® program to simulate different conditions (e.g. dry weather and wet weather conditions). The development of each working model used the plant configuration and performance data for layout construction, calibration and validation. The NVEC WWTP models were developed and calibrated using only the 2001 plant data. Monthly and wet/dry weather averages of the year 2001 data were used for the model validations.

3.2 NORM WOOD ENVIRONMENTAL CENTER WASTEWATER TREATMENT PLANT (NVEC WWTP)

3.2.1 Current Condition

1. Influent Flow and Loads

The system design criteria of Stage 1a (design population 37,000 PE, Dayton & Knight, 1997) and Stage 1b (design population 52,000 PE) are listed in Table 3.1, along with the 2001 dry weather and 2001 wet weather averages. Lower flow and loads are designed for the Stage 1a. Stage 1b represents the ultimate design capacity of existing facility. Current flow conditions and influent loads are within the Stage 1b design capacity of each unit process.

The average sewage influent flow rates (during 1999 to 2002) are shown in Figure 3.1, including the annual averages, maximum monthly averages, and maximum day flows. The current maximum monthly average is approximately 20,300 m³/d, which is about 13% below the Stage 1a (23,500 m³/d, 37,000 service population), and 38% below the Stage 1b design capacity (33,100 m³/d, 52,000 service population).

The maximum daily flow recorded in 2001 was about 29,800 m³/d, which has exceeded the Stage 1a design capacity. The headworks screening design capacity of 23,700 m³/d would have been overloaded by these peak

**DISTRICT OF CAMPBELL RIVER
LONG TERM SEWAGE TREATMENT STUDY**

flows. High hydraulic loads have caused significant impact on the system performance, particularly to the secondary clarifiers. The plant staff has reported peak daily flows exceeding 30,000 m³/d and solids carryover occurred in the secondary clarifiers during the high flow events.

TABLE 3.1: NVEC WWTP DESIGN CRITERIA AND 2001 PLANT DATA

Stage	Unit	1a	1b	2001 Dry*	2001 Wet*
Design Population		37000	52000	30295	30295
Influent					
Temp	C			19.2	12.4
Average annual flow	m3/d	16900	23700	13255	17237
Peak day flow	m3/d	29500	41400	15322	29748
Peak monthly flow	m3/d	23500	33100	14100	20306
BOD5	mg/L	220	220	154	128
SBOD5	mg/L	110	110	-	-
TSS	mg/L	200	200	142	175
NH3-N	mg/L	20	20	18	15
BOD5 load	kg/d	3718	5214	2041	2206
SBOD5 load	kg/d	1859	2607	-	-
TSS load	kg/d	3380	4740	1882	3016
NH3-N load		338	474	239	259
Screen					
hydraulic capacity	m3/d	23700	23700		
Oxidation ditches					
units	-	2	2	1	1
volume/tank	m3/d	8203	8203	8203	8203
ditch nominal width	m	17	17	17	17
depth	m	2.70	2.70	2.70	2.70
detention time	hr	23.30	16.61	14.85	11.42
mean forward velocity	m/min	0.26	0.36	0.20	0.26
MLSS	mg/L	4000	4000	3960	3640
MLVSS	mg/L	3200	3200	3111	2924
MLVSS/MLSS	-	0.80	0.80	0.79	0.80
BOD5 loading	kg/m3/d	0.23	0.32	0.25	0.27
F/M ratio	kg BOD5/MLVSS/d	0.07	0.10	0.08	0.09
Solids retention time	d			13.6	12.3
Return sludge					
Return sludge rate	m3/d			11324	10878
RAS MLSS	mg/L			7610	7514
RAS MLVSS	mg/L			6088	6086
RAS MLVSS/MLSS	-			0.80	0.81
Aeration demand					
carbonaceous O2 demand	kg O2/d	5577.00	7821.00	3061.91	3309.50
nitrogenous O2 demand	kg O2/d	1487.20	2085.60	1049.80	1137.64
Total O2 demand	kg O2/d	7064.20	9906.60	4111.70	4447.15
Total air requirement	L/s				
yield	-	0.75	0.75		
Solids production	kg/d	2788.50	3910.50		

*: With one oxidation ditch in operation

**DISTRICT OF CAMPBELL RIVER
LONG TERM SEWAGE TREATMENT STUDY**

TABLE 3.1: NVEC WWTP DESIGN CRITERIA AND 2001 PLANT DATA (CONT'D.)

Stage	Unit	1a	1b	2001 Dry*	2001 Wet*
Clarifier					
Unit	-	2	2	2	2
diameter	m	27	27	27	27
side water depth	m	5	5	5	5
area/unit	m ²	572	572	572	572
weir length/unit	m	78	78	78	78
overflow rater	m ³ /m ² /d	14.77	20.71	11.58	15.06
weir overflow rate	m ² /m/d	108.33	151.92	84.97	110.49
detention time	hr	8.13	5.80	10.36	7.97
underflow TS conc.	mg/L			6116	6088
Underflow VS conc.	mg/L			4892	4931
Peak day overflow rate	m ³ /m ² /d	25.77	36.17	13.4	26.0
Solid loading	kg/m ² /d			83.8	88.3
Aerobic digester					
unit	-	1	1	1	1
depth	m	4	4	4	4
volume	m ³	6000	6000	6000	6000
Flow rate	m ³ /d			347	344
Supernatant	m ³ /d			192	196
underflow	m ³ /d			117	144
Reactor TSS	mg/L			10806	9314
Waste sludge TS	mg/L			13938	12479
Supernatant TSS conc.*	mg/L			1000	1000
solid loading	kg/d			2609	2316
hydraulic detention time	d			17.3	17.4
solids retention time	d			35.6	28.0
Biosolids storage basin					
depth	m	4	4		
volume	m ³	18152	18152		
total air requirement					
Effluent					
pH	-			6.3	6.5
BOD	mg/L	45	45	10	10
TSS	mg/L	45	45	8	6

*: With one oxidation ditch in operation

FIGURE 3.1: NVEC WWTP AVERAGE FLOW RATES

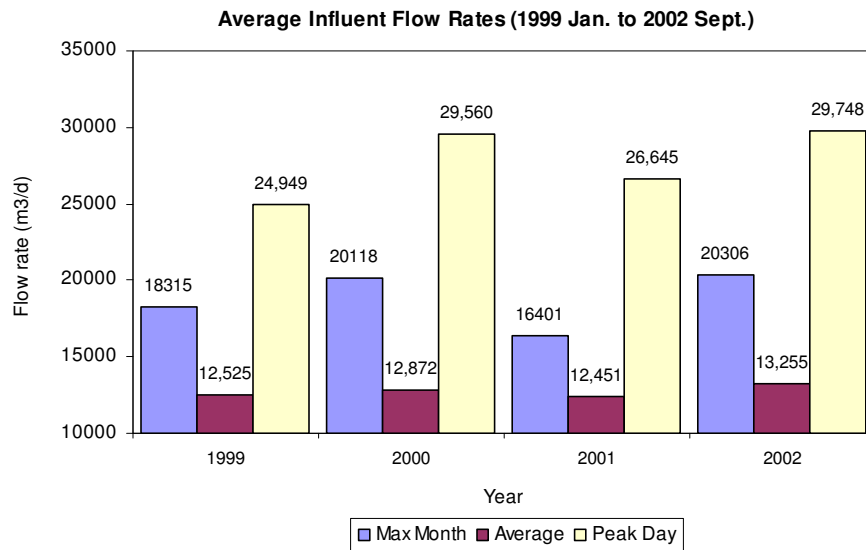

The monthly average flow rates (from January 1999 to September 2002) are shown in Figure 3.2. The wet weather flows (typically in November, December, January and February) were found to be about 1.6 times of the dry weather flows (typically during May to September). These seasonal flow variances suggested that different operational conditions could be arranged to optimize the treatment efficiency, i.e. different mixed liquor suspended solids (MLSS) concentrations in the oxidation ditches.

The monthly average TSS and BOD loads are illustrated in Figure 3.3 and 3.4. Current TSS loads are about 40% below the Stage 1b design capacity (4,740 kg/d of TSS). Since there is no primary treatment available, the peak daily flow and maximum TSS loads could have significant impact on the secondary clarifier performance. The average BOD loads are still less than 50% of the Stage 1b design capacities (5,210 kg/d of BOD). This supports the need to operate only one oxidation ditch under current flow conditions. However, both oxidation ditches should be brought to service in the near future as the influent loads increase.

Current BOD load, F/M ratio, and solids retention time (SRT) in the oxidation ditch are within the typical ranges of extended aeration mode guidelines. Considering that only one oxidation ditch is in service, there is sufficient capacity to treat almost double the current organic loads when two oxidation ditches are both in use. Further, the treatment efficiency can possibly be enhanced substantially by upgrading the aeration system in the oxidation ditches (e.g. aeration sequence and DO set-point controls).

FIGURE 3.2: MONTHLY AVERAGE FLOW RATE OF NVEC WWTP

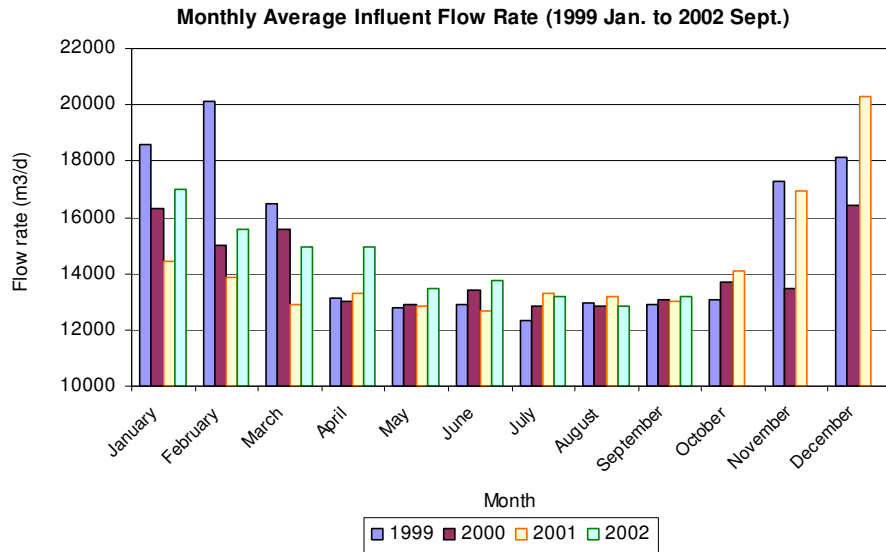

FIGURE 3.3: MONTHLY AVERAGE SOLIDS LOADS OF NVEC WWTP

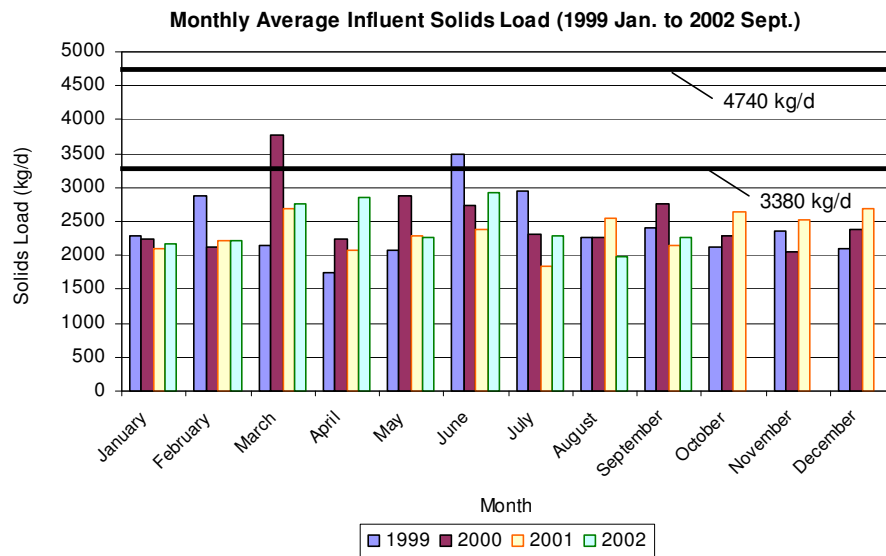
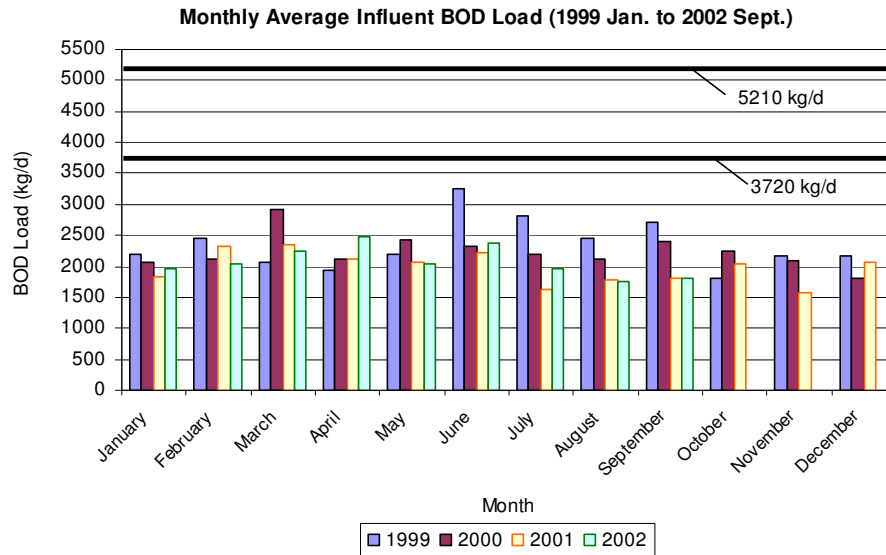

FIGURE 4: MONTHLY AVERAGE BOD LOADS OF NVEC WWTP



2. Effluent Quality

The treatment system has consistently achieved higher than 90% of BOD and TSS removal efficiencies in the past years. The average effluent quality of 2001 in terms of TSS and BOD concentrations were below 10 mg/L of BOD and 10 mg/L of TSS. The system achieved certain levels of total nitrogen removal and occasionally complete nitrogen removal. The possible dominant route of nitrogen removal is likely to be the biological nitrification and denitrification reactions, due to the air ON/air OFF arrangement in the oxidization ditch. Ammonia nitrogen is first been converted into nitrite and nitrate (NO_x) by means of nitrification during the aerated period, and then consequently been converted into nitrogen gas by means of denitrification during the non-aerated period (or anoxic condition). The computer modeling demonstrated the fluctuations of nitrogen species concentrations in the final effluent due to the air on/air off scheduling (i.e. the nitrification and denitrification sequences). Typical model simulation results of final effluent ammonia-N and NO_x-N concentrations are illustrated in Figure 3.5.

FIGURE 3.5: MODELING RESULT OF FINAL EFFLUENT

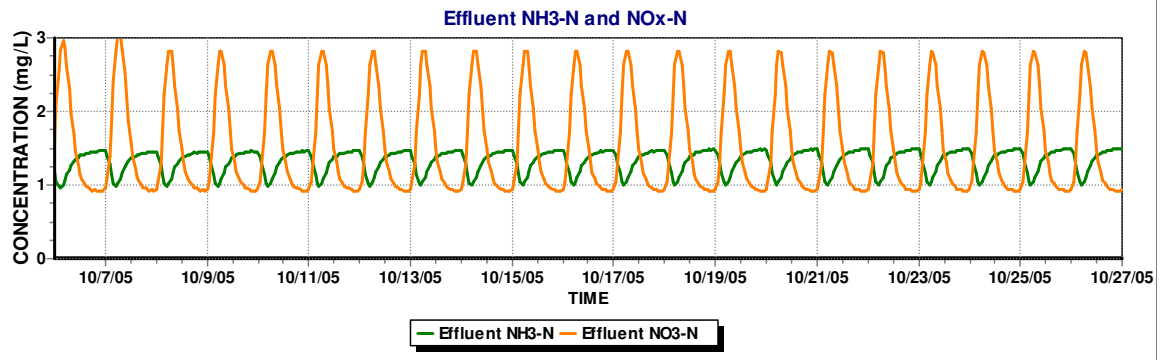

Nitrification can reduce the effluent toxicity level significantly by reducing the ammonia-N concentration. However, nitrification requires significant amount of air and alkalinity demands for ammonia oxidation. Denitrification can further convert the NO_x into nitrogen gas and recover some alkalinity, while readily biodegradable carbon source is available. Operational and system retrofits can be considered (e.g. aeration schedule and zone segments) to enhance the effluent quality and to reduce the chemical costs (lime addition). Possible aeration and chemical savings concluded by the computer model simulations are discussed later in the section of Future Projections (Section 3.2.2).

3. Oxidation Ditches

The system is currently operated with only one oxidation ditch at a time due to low influent loads. Since there is no grit removal in front of the oxidation ditches, grit are commonly found to deposit at the front end of the ditches. The grit deposit needs to be removed from the oxidation ditches by alternating the operation between the oxidation ditches. Meanwhile, alternating between the two ditches also requires acclimation time for the biological system during transition, which may cause system instability. The installation of grit removal units is recommended for operating both oxidation ditches in parallel and maximizing the treatment capacity.

One of the oxidation ditch is recently used for sludge storage in between the silviculture applications. This arrangement has limited the capability to alternate the operation between two oxidation ditches for grit cleaning. As the flow and loads increase, both oxidation ditches need to be operated within one to two years for providing the same level of treatment. Alternative for temporary sludge storage needs to be revisited.

The aeration in the oxidation ditches is controlled by dissolved oxygen (DO) and oxidation-reduction potential (ORP) set points to optimize the

carbonaceous BOD and nitrogen removal. The current aeration schedule is based on a three-hour cycle with aeration ON for two hours at DO 3.0mg/L level, and air OFF for the third hour. The ORP monitoring signal is applied to override the aeration schedule when necessary. During the air OFF period, the aeration will be brought back online if an “ORP nitrate knee” is observed (indicating the depletion of NO_x in system), and the aeration cycle will be restarted again. This air ON/OFF and DO/ORP control arrangement has demonstrated benefits to achieve high treatment efficiency.

Proper DO and ORP monitoring for the aeration control can enhance the treatment efficiencies (carbonaceous and nitrogen removals) as well as the aeration saving. The aeration cycle can be further fine-tuned, such as shorter aeration period, for optimizing nutrient removal and saving energy. A degree of alkalinity recovery can also be achieved by the denitrification occurred during the air OFF period. Currently, there is only one set of DO and ORP probes available in each oxidation ditch. According to other pilot and full-scale experiences, a minimum of two sets of DO and ORP probes are recommended to assure the signal quality and control accuracy. More efficient blower control is also necessary in the scheme to optimize the DO/ORP control and save energy. Variable frequency drive (VFD) for the blower control is commonly used in the full-scale plants to prevent blower wear and tear, as well as better DO control.

External chemical addition in the aerobic digester is necessary due to low pH and low buffer capacity in the raw sewage influent. The oxidation of ammonia-nitrogen into nitrite and nitrate during the nitrification requires significant amount of alkalinity. Calcium hydroxide (lime) is periodically supplemented to the aerobic digester, at approximately 3,600 to 4,500 kg per month, to adjust the pH condition and supply the alkalinity demand of biological nitrogen reactions. Some alkalinity supplement will be recycled back into the oxidation ditches through the digester supernatant return. Certain degree of alkalinity will be recovered in the denitrification reaction; however, a net alkalinity demand will still persist. The total alkalinity demand can be minimized by preventing the nitrification reaction in the oxidation ditches and aerobic digester (when the nitrogen removal is not required). Practically, the nitrification can be suppressed by operating the process with low SRT. Internal recovery of alkalinity can also reduce the requirement of external lime addition by maximizing the degree of denitrification (i.e. complete denitrification).

4. Aerobic Digester

The aerobic digester is currently operated with scheduled aeration between four diffuser grids. A period of gravity settling is scheduled to allow the supernatant recycling and settled biosolids withdraw. The digester supernatant is returned back to the oxidation ditches for treatment, and the

digested biosolids are stored in the adjacent basin for future thickening. Currently, silviculture is arranged for the final biosolids reuse, and this land application has been planned for the next 15 years. The digested biosolids typically have the specific oxygen utilization rate (SOUR) below 2.0 mg//hr/g MLVSS, and the average total coliform counts below 1,000,000 MPN/100mL.

The SRT in the digester was found to be about 30 days in average. Compared to the conventional degree-day curve for the volatile solids (VS) destruction, the existing system achieved satisfactory VS destruction at about 38%. However, the efficiency of VS destruction is subject to the operational conditions, including aeration, mixing, alkalinity supplement and pH level. The plant staff has reported the difficulty of aeration and mixing control in the digester, mainly due to the oversized blowers and lack of mixing devices. Excessive aeration due to the mixing requirement may cause extra alkalinity demand consumed in the nitrification reaction. Advanced aeration controls (e.g. blower VFD and DO set point controls) and submersible mechanical mixer to provide sufficient mixing power are recommended to enhance the digester operation.

The existing digester has reached the system capacity under current flow and operational conditions to meet the designed performance (i.e. pathogen and volatile solids reductions). As the sludge flow and loads increased, the stabilization efficiency in the digester will be gradually degraded. To satisfy the minimum HRT and SRT in the system, the sludge needs to be further thickened to increase the concentration, otherwise, expansion or other alternates, such as composting and anaerobic digester, need to be considered to meet the treatment requirement (e.g. BC organic Material Recycling Regulation Class B biosolids). The sludge stabilization practice should be considered jointly with the District's biosolids reuse program and implementation plan (e.g. composting, silviculture land application, and others).

5. pH and Alkalinity

By optimizing the denitrification in the oxidation ditches, and eliminate the nitrification in the digester, the total alkalinity demand can be reduced and the external lime supplement can be minimized. Even with the maximum alkalinity recovery from the denitrification, lime supplement may still be necessary because of the low pH and low alkalinity in the raw influent sewage. Model simulations demonstrated the possibility of decreasing alkalinity demand by shortening the aeration time in the oxidization ditches (see Section 3.2.2). Nitrification during aerobic digestion may be inevitable due to the minimum SRT requirement for the VS destruction, however, by proper control of aeration may minimize the degree of nitrification. By reducing the biosolids retention time in the aerobic digester, lime saving is

also possible if the minimum degrees of VS destruction and pathogen kill can be maintained.

6. Secondary Clarifiers

Currently, both clarifiers are online in service and satisfactory solids removal efficiency can be achieved under average flow conditions. The surface overflow, weir overflow, and solids load rates were found to be within the range of typical design guidelines. However, during peak flow events, the surface overflow rate has exceeded $25 \text{ m}^3/\text{m}^2/\text{d}$ when the flow reached $30,000 \text{ m}^3/\text{d}$. This excessive surface overflow rate was mainly due to the high MLSS concentration maintained in the oxidation ditches resulting in high solid surface load (above $150 \text{ kg}/\text{m}^2/\text{d}$). The MLSS concentration in the oxidation ditches can be reduced by operating both oxidation ditches at all times. The hydraulic impact on the clarifiers can also be mitigated by reducing the peak daily flow, if possible (i.e. I/I control in the collection system). The flow of return activated sludge (RAS) should be reevaluated to reduce the hydraulic and solids loadings in the secondary clarifiers during the high flows. One possible solution is to modify the RAS control protocol and reduce the RAS flow during high flow condition. Instead of constant recycling (i.e. 90% of the flow), reduced RAS flow can be designed in accordance with the influent flow increase. Alternatively, extra clarifiers are needed to secure the solids removal efficiency.

The hydraulic heads of the clarifier influent and effluent between two clarifiers are not equal due to different distances. These may result in uneven flow distribution between two clarifiers and effluent backwater particularly during the peak flow events. Insufficient hydraulic capacity of the effluent pipe and effluent channel has caused the backwater to flood the clarifier weirs. Modification of the flow distribution and effluent pipe hydraulic capacity is necessary to meet high flow load, and this retrofit can be implemented in accordance with the future plant upgrade plan (e.g. additional clarifiers).

3.2.2 Future Projection

1. Degrees of Treatment and Effluent Quality Aspects

The computer model was used to assess the NVEC WWTP system capacity under wet weather condition (worst-case scenario at the maximum monthly flow and winter temperature), to deliver three different degrees of treatment and effluent qualities:

- Case 1: Nitrification and partial denitrification with current aeration ON/OFF arrangement. Grade **A+** effluent quality.
- Case 2: Conventional secondary treatment and nitrification only (high SRT). Grade **A** effluent quality.
- Case 3: Conventional secondary treatment only with full aeration (low SRT). Grade **B** effluent quality.

With nitrification and partial denitrification in Case 1, ammonia toxicity and total nitrogen loads in the effluent to the Discovery Passage are minimized. In comparisons among these three effluent qualities, current plant operation achieves Case 1 effluent quality (Grade A+), which is superior to the design effluent quality Case 2 (Grade A). Biological ammonia removal will be limited in Case 3 due to the loss of nitrification.

In Case 1, the air ON/OFF (two hours ON and one hour OFF) at 2 mg/L of DO set point was operated in the oxidation ditches. Carbonaceous BOD and biological nitrogen removal (nitrification and partial denitrification) can be expected with this aeration arrangement. In Case 2, full aeration cycle at 2 mg/L of DO set point is operated, and aerobic condition is maintained at all times. The system will provide conventional secondary treatment (BOD removal) and complete nitrification if possible. The denitrification will be suppressed due to lack of anoxic cycle. In Case 3, solids retention time (SRT) in the oxidation ditches is reduced to between 3 to 5 days. The system will lose most of the nitrification capability and only achieve conventional secondary treatment of BOD removal. The system capacity of Case 3 can be referred as the system maximum capacity with the least degree of treatment.

The effluent qualities of each treatment case are projected in Table 3.2. Theoretical calculation suggested that the non-ionized ammonia concentration in the Case 3 effluent poses no significant concern in toxicity. The effluent ammonia-N concentration is below the Federal standard at 16 mg/L, which is expected to be enforced in 2005. However, further ratification with the BC Ministry of Water Land and Air Protection (BC MWLAP) is recommended.

TABLE 3.2: TARGET EFFLUENT QUALITIES OF DIFFERENT DEGREES OF TREATMENT

Paramerter	Unit	Case 1	Case 2	Case 3
BOD	mg/L	< 45	< 45	< 45
TSS	mg/L	< 45	< 45	< 45
NH3	mg/L	<2	<2	14
NOx	mg/L	<3	~12	0

The treatment capacities at the maximum monthly flows are estimated for each treatment case. The estimated capacities of each case are shown on Figure 3.6, in accordance with the flow projections at different population growth rates. At a 2.5% population growth rate scenario, the maximum monthly average flow will reach the Case 1 system capacity by 2006 (limited by the secondary clarifier). The maximum monthly flow will reach Case 2 and Case 3 system capacities by 2014 and 2020, respectively.

Figure 3.6: Treatment System Capacity Projections at 2.5 % Population Growth Rate

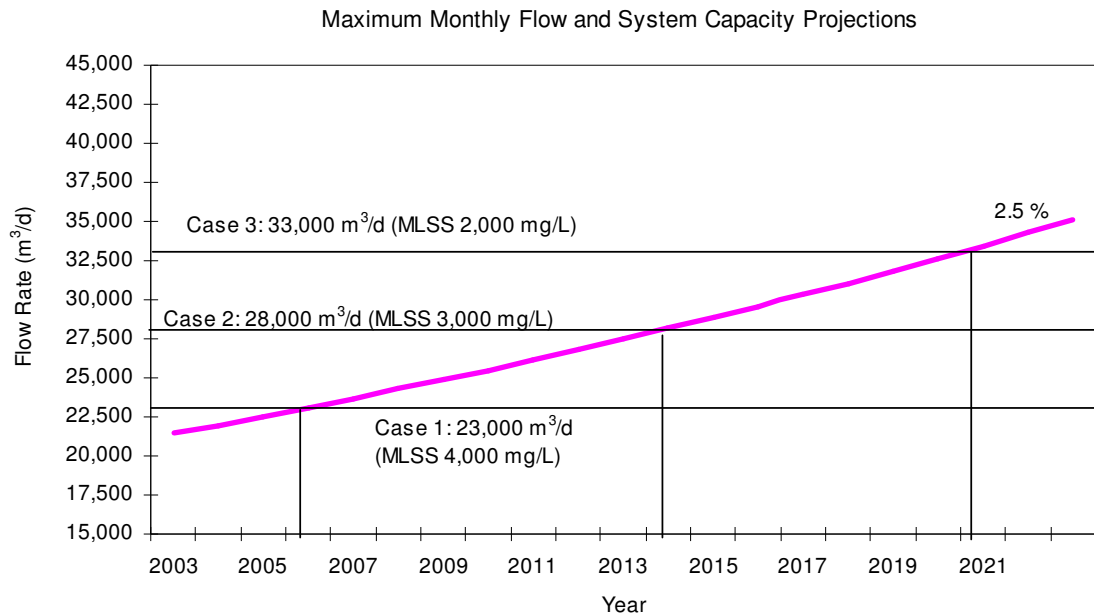

Model simulations also provide information for the unit process re-rating, in which the secondary clarifiers were found to be the system bottleneck (excessive solids loading in the clarifiers). The service years of the treatment system can be prolonged substantially by expanding the clarifier capacity. The timelines for the clarifier upgrade are also shown in Figure 3.6, for example, by adding two extra clarifiers, the treatment capacity of Case 1 can be extended to 28,000 m³/d (maximum monthly flow rate), which is equivalent to about 41,000 PE (by the year of 2013 at 2.5 % population growth rate). Further upgrade options are discussed in Section 4.1.

2. Aeration and Alkalinity Requirement

Aeration schedules in the oxidation ditches and the aerobic digester were evaluated by using the model simulations. These exercises were designed to investigate the possible savings of aeration energy and lime chemical

(alkalinity equivalent) without deteriorating the treatment efficiency. Currently, lime addition is implemented only in the aerobic digester; however, some alkalinity is returned to the oxidation ditches through the digester supernatant recycling. Conceptual flow and system conditions were based on 2001 dry weather flow (high temperature with low oxygen solubility and aeration efficiency) and their aeration schedules are summarized in Table 3.6.

TABLE 3.6: MODEL SIMULATION SCENARIOS

Conditions	Aeration Schedule	Aeration time
Scenario 1	DO set point at 2.0 mg/L	24hr
Scenario 2	DO set point at 2.0 mg/L, air on for 2hr, air off for 1 hr	16hr, 8 cycles/day
Scenario 3	DO set point at 2.0 mg/L, air on for 1.5 hr, air off for 1.5 hr	12hr, 8 cycles/day

- Oxidation Ditches

The simulation results of three scenarios have demonstrated that the effluent qualities were not significantly affected by the reductions of aeration time, in terms of BOD and TSS removal efficiencies. Generally, the effluent BOD and TSS concentrations in three scenarios were below 45 mg/L. Full nitrification can be achieved in Scenario 1, with a limited degree of denitrification. The ammonia-N concentration was found to be below 2 mg/L and NOx-N concentration below 5 mg/L in Scenario 1. Slightly increase of ammonia-N concentration in Scenarios 2 and 3 were mainly due to the reduction of aeration time. The effluent ammonia concentrations in all three scenarios were below 6 mg/L. Certain degree of denitrification occurred in Scenarios 2 and 3 resulting in total nitrogen removal and alkalinity recovery.

The aeration demands (at 20 °C, 1 ATM) in the oxidation ditches are compared in Figure 3.7a. The air demands in Scenario 2 and Scenario 3 have been reduced by 16% and 38% from the Scenario 1 level. Simulation results suggested potential energy saving by shortening the aeration ON/OFF cycle, without significant effect on the effluent quality.

The net alkalinity consumption (lime chemical equivalent) in the oxidation ditches for three scenarios are also compared in Figure 3.7b. The alkalinity consumptions in Scenario 2 and Scenario 3 have been reduced by 33% and 68% from the Scenario 1 level. These reductions of alkalinity consumption are mainly due to the decrease of nitrification and increase of denitrification. Results suggested potential chemical saving by the air ON/OFF scheduling and reducing the aeration time, if lime addition is needed in the system.

- Aerobic Digester

Three conceptual aeration scenarios were also simulated in the aerobic digester. The mixing power was assumed not to be the limiting factor in all three scenarios regardless of their aeration rates. The specific oxygen utilization rates (SOUR) were below 1.0 mg/hr/g in three scenarios. By decreasing the aeration rate, the degree of nitrification was reduced, which resulted in less alkalinity consumption (less lime demand).

The air demands (at 20 °C, 1 ATM) in the aerobic digester are compared in Figure 3.8a. The aeration demands in Scenario 2 and Scenario 3 have been reduced by 16% and 42% from the Scenario 1 level. The net lime consumption in oxidation ditches of three scenarios are also compared in Figure 3.8b. The net lime consumptions in Scenario 2 and Scenario 3 have been reduced by 97% and 100% respectively, from the Scenario 1 level. Simulation results suggested potential aeration and chemical savings by ON/OFF aeration scheduling, in which the degree of nitrification was minimized. However, pathogen reduction was not simulated in the model and further assessment is needed to assure the pathogen kill rate. Also, a certain amount of lime addition may be inevitable due to the need of pH adjustment, therefore, the chemical saving predicted by the model should not be considered as the actual values.

FIGURE 3.7: MODEL SIMULATION RESULTS OF AERATION DEMAND AND NET LIME CONSUMPTION IN OXIDATION DITCHES

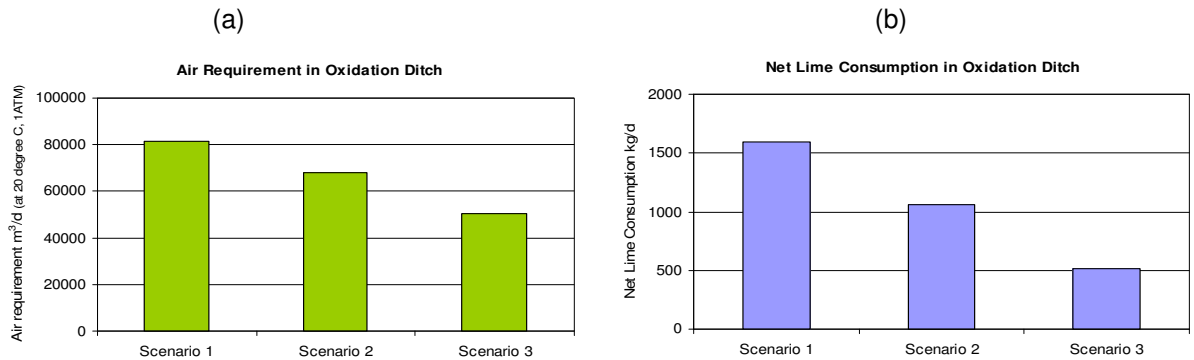
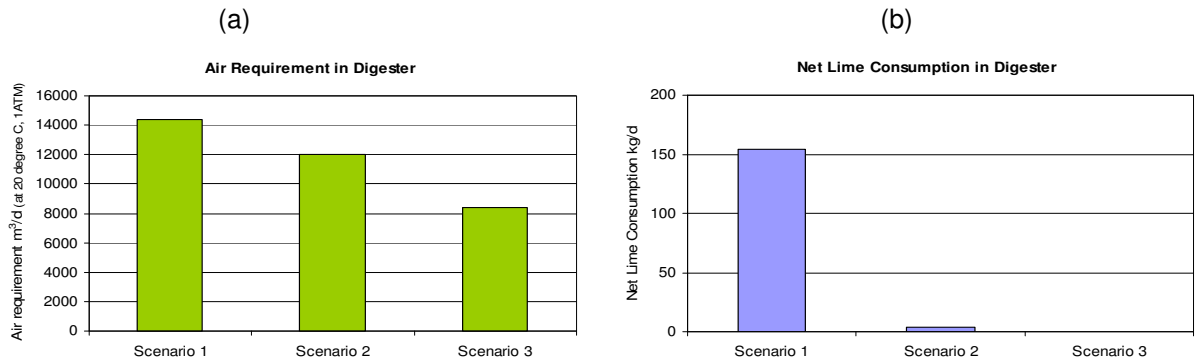

FIGURE 3.8: MODEL SIMULATION RESULTS OF AERATION DEMAND AND NET LIME CONSUMPTION IN AEROBIC DIGESTER



The results also indicated the potential benefits of implementing advanced aeration control, such as blower VFD operation and DO set point monitoring. Aeration optimization should be considered by DCR for maximizing the treatment efficiency and economic saving in long term. Full-scale tests are recommended to verify these potential benefits.

3.3 INDUSTRIAL PARK LAGOON (IPL)

3.3.1 Current Condition

The existing Industrial Park Lagoon (IPL) is a 6,200 m³ un-aerated facultative lagoon designed for low flow and light loads generated from the Industrial Park lots. The facultative lagoon system has an aerobic zone at the surface where oxygen is maintained by algae and surface aeration, and an anaerobic zone at the bottom layer. Organic matters are decomposed in both zones with the treatment rate limited by the rate of anaerobic decomposition and reaeration that is possible. The advantageous factors associated with the facultative lagoon are the minimum maintenance requirements and low operational costs (e.g. aeration and pumping).

A plant schematic is illustrated in Figure 3.9, showing the approximate locations of the north inlet, south inlet and outlet. The north inlet collects the wastewater generated from the Industrial Park Phase I lots, and the south inlet collects the wastewater produced from the composting operation. The outlet takes the effluent overflow and discharges through the outfall into the Discovery Passage.

FIGURE 3.9: SCHEMATIC OF THE INDUSTRIAL PARK LAGOON PLANT LAYOUT

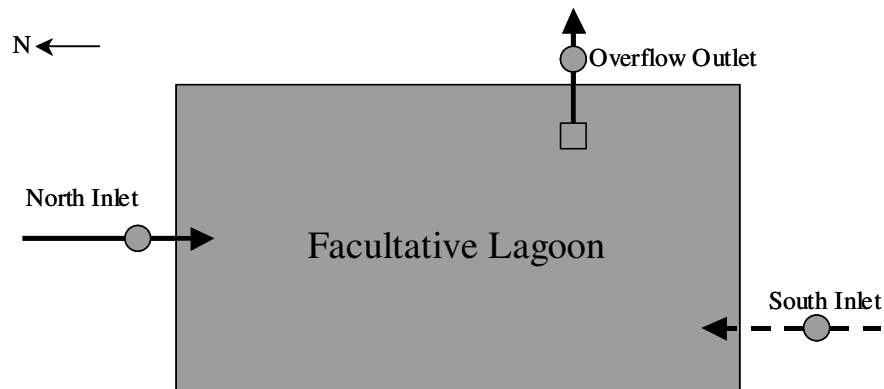

The 1999 plant data showed that the IPL provided satisfactory effluent qualities of BOD below 45 mg/L and TSS below 60 mg/L. The influent BOD and TSS loads were below 4 kg/d and 2 kg/d, respectively, while the influent flows averaged about 20 m³/d. The effluent qualities deteriorated substantially during the months of November and December 1999, when the influent flows increased to above 50 m³/d, with a BOD and TSS load of 17 kg/d and 9 kg/L, respectively.

High organic and hydraulic loads entering the lagoon system in 2000~2002 has caused significant impacts to the treatment system and resulted in compliance violations of effluent quality. The plant data suggested that the cause was heavy organic and solid loads generated from the adjacent composting facility, combined with the hydraulic shock load during the wet weather season and storm events. Historical data also revealed that the high inflows during the wet weather were primarily from surface runoff in the Industrial Park catchments. Records also showed that the composting operation was the main source of BOD and TSS entering from the south inlet.

The system design criteria for the IPL, based on the Recommended Standards for Wastewater Facilities (Great Lakes-Upper Mississippi River Board of State and Provincial Public Health and Environmental Managers, 1997), known as the Ten-State Standards, are summarized in Table 3.3. The maximum allowable influent BOD concentration is approximately 145 mg/L at a flow rate of 68 m³/d.

TABLE 3.3: FACULTATIVE LAGOON DESIGN CRITERIA

Parameter	Values	Remarks
Volume	6176 m ³	
Surface area	2480 m ² (0.248 hectares)	Top surface
Lagoon depth	4 m	Maximum depth
Design HRT	90-120 days	
Design influent flow rate	51-68 m ³ /d	Average flow
Design BOD application	17-40 kg/hectare/d	
Design influent BOD ₅ loading	4.2-9.9 kg/d	
Design influent BOD ₅ conc.	61-194 mg/L	Between the lowest BOD ₅ loading/the lowest HRT and highest BOD ₅ loading/highest HRT

The IPL performance was evaluated by using the plant data from 2001 and 2002. The significant findings are summarized as follows:

1. The influent hydraulic and BOD₅ loading during the summer dry weather season averaged about 120 days of HRT and 5 kg/d of BOD loading. These values were within the design criteria ranges summarized in Table 3.3. In comparison with the typical design criteria, these hydraulic and organic loads are considered among the lower range of system capacity without aeration system in place.
2. The plant performance was significantly affected by the fluctuation of influent hydraulic and organic loadings. The daily flows during July 2000 to October 2002 are shown in Figure 3.10. Influent flows as high as 200 to 350 m³/d were frequently experienced, particularly during the winter wet weather season and storm events. The highest flow was found to be about 8 times higher than the summer dry weather average of 50 m³/d. These high flows were most possibly coming from the surface runoff or storm drainage within the catchments, rather than the process wastewater generated from the Industrial Park. The influent flows have exceeded the design capacity (51-68 m³/d), which significantly reduced the retention time required in the lagoon.
3. The calculated HRTs during the high flow events were reduced to about 20 - 30 days without considering any short-circuiting of flow in the pond. Insufficient HRT probably resulted in the decline of BOD and TSS removal efficiency. High flow events can potentially cause short-circuiting and result in reduction in the actual HRT due to a non-ideal hydraulic pattern in the pond. High influent flow rates may also increase the hydraulic surface loading and cause sediment to re-suspend and result in high BOD and TSS concentrations in the final effluent.

4. The influent BOD and TSS loadings were significantly higher during the winter wet weather season than during the summer dry weather. However, the precise loads from the north and south inlets are unknown. The winter organic loadings during 2000 to 2002 were estimated to be as much as 20 times higher than the summer season average, assuming that most of the additional loads were attributable to the runoff from the adjacent composting site. Currently, there is no detailed storm drainage system information available, further investigations are needed, e.g. smoke or dye tests to confirm these speculations.
5. The facultative lagoon was designed for a low flow, low loading scenario. Apparently, current influent flows and loads have reached the IPL system capacity with the discharge from the adjacent composting site. Improvements to the facility such as hydraulic condition and partial aeration can increase the treatment capacity. Source controls such as pretreatment and surface runoff interception are also critical to a successful lagoon operation.

FIGURE 3.10: IPL DAILY FLOW RATES

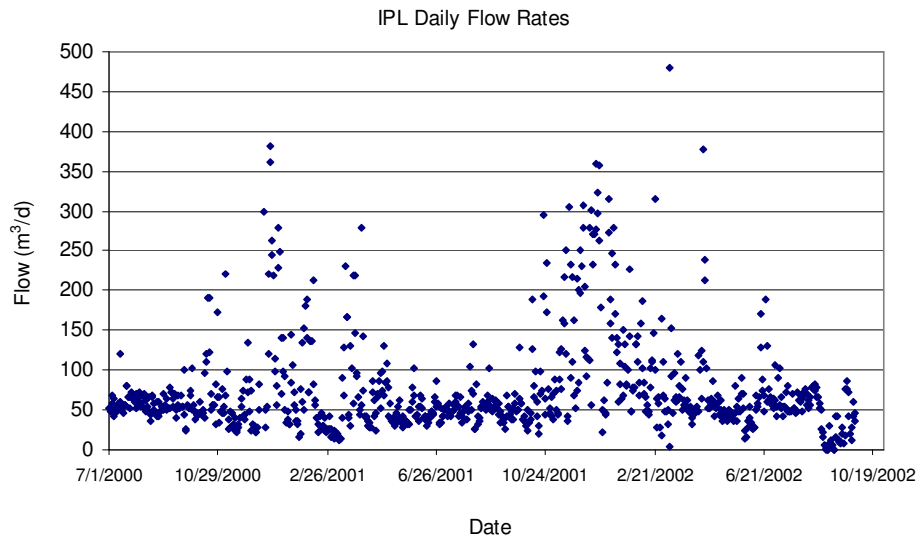

6. With the disconnection of the Renuable composting effluent waste in late 2002, the lagoon system appears to be recovering. The records during early 2003 to mid 2004 showed that the flow rate averaged about 20 m³/d, which is significantly lower than the period with the Renuable composting waste discharge. The average effluent concentrations of BOD₅ and TSS reduced gradually from 70 and 50 mg/L in 2003, to about 25 mg/L and 40 mg/L in 2004, respectively. However, source control and monitoring program should be continued and expanded to assure the influent flow and loads are within the design ranges and bylaw limits.

3.3.2 Future Projection

The projections of the IPL treatment were based on the degree of aeration, including un-aerated (facultative) and partially aerated modes. In all scenarios, it is assumed that hydraulic flow conditions have been upgraded to achieve an ideal “quasi” plug flow pattern. The upgrade includes relocating the inlets and installing floating curtain baffles.

The treatment system capacity in terms of BOD removal was evaluated using the Wehner and Wilhelm kt equation (EPA, 1986), and Biowin32 model simulation (Biowin32 version 1.1.2, 2000). Partial aeration was considered in the capacity projections by converting a portion of lagoon into aerated zone, and using the remaining volume as non-aerated facultative pond. Four scenarios have been examined, including no aeration, 25%, 50% and 75% aeration volume, respectively.

The design parameters and assumptions are summarized in Table 3.4. The projected effluent BOD concentrations at wintertime temperature (10 °C) using Biowin 32 model simulation are shown in Figure 3.11. The capacity assessment is based on the worst-case scenario, such as the lowest wastewater temperature (wintertime) and highest hydraulic loading (wet weather flow). The solids removal efficiency may vary widely depending on seasonal algae growth. The Ten-State Standards recommends that the minimum un-aerated (facultative) zone volume must be at least 30% of the aerated zone volume (2 - 4 days of HRT). The non-aerated zone, namely the facultative zone, is required for solids settling and final polishing prior to final discharge.

**DISTRICT OF CAMPBELL RIVER
LONG TERM SEWAGE TREATMENT STUDY**

TABLE 3.4: LAGOON PERFORMANCE ASSESSMENT WITH AERATION

Parameters	Scenario I	Scenario II	Scenario III	Notes
Total basin volume, m ³	6170	6170	6170	
Effective volume, m ³ (% of effective basin volume)	5244 (85)	5244 (85)	5244 (85)	Due to sediment and dead space
Surface area, m ²	2480	2480	2480	
Basin depth, m	4	4	4	
North inlet (baseline flow and load)				
Flow rate	50	50	50	
BOD, mg/L (kg/d)	100 (5)	100 (5)	100 (5)	
TSS, mg/L (kg/d)	100 (5)	100 (5)	100 (5)	
South inlet				
Flow Rate	0-200	0-200	0-200	
BOD, mg/L	500	500	500	
TSS, mg/L	500	500	500	
Aerated zone				
Aerobic zone volume, m ³ (percentage of total effective volume, %)	1311 (25)	2622 (50)	3933 (75)	
Dissolved oxygen, mg/L	2.0	2.0	2.0	
Facultative zone				
Facultative one volume, m ³ (percentage of total effective volume, %)	3933 (75)	2622 (50)	1311 (25)	
Temperature of wastewater				
Summer, °C	20	20	20	
Winter, °C	10	10	10	

FIGURE 3.11 IPL EFFLUENT BOD PROJECTIONS WITH AERATION

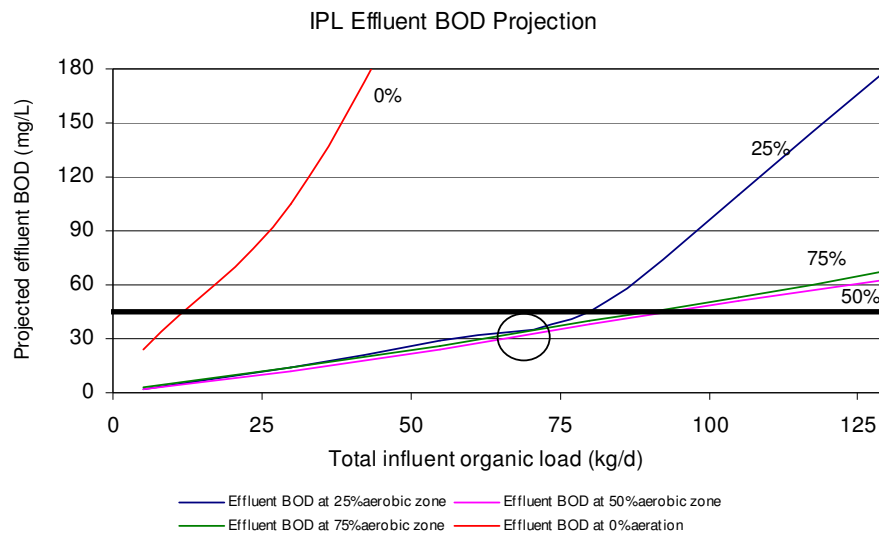

The results of process modeling and Wehner and Wilhelm kt equation suggested the optimized aerated zone is about 50% of total effective volume to achieve effluent BOD concentration below 45 mg/ L. The estimated treatment capacity by converting 50% of volume into aerated lagoon is about 70 kg/d of BOD at 380 m³/d flow rate. The system capacities and service PE of three upgrade options are summarized in Table 3.5. Rather than projecting the timelines, the treatment capacity of each upgrade option is provided for future decision.

TABLE 3.5: IPL SYSTEM UPGRADE CAPACITY

Upgrade system	Flow	BOD	TSS	Service Capacity
	m ³ /d	kg/d	kg/d	PE
Existing Facultative Lagoon*	70	10	10	100
Aerated Lagoon**	380	70	70	600
Convey to NWECC for Treatment	Subject to ultimate NWECC expansion capacity			

*: with hydraulic upgrade only

**.: with hydraulic upgrade and 50% volume of aeration zone

4.0 SYSTEM UPGRADE OPTIONS AND COST ESTIMATES

4.1 GENERAL

The system upgrade options and timely schedule of implementation are developed based on the system capacity evaluation discussed in Section 3. The objectives of upgrades are to maximize the treatment capacity with existing infrastructure and accommodate the future demands. Cost estimates of each upgrade option are also provided accordingly.

The IPL system recently experienced high organic and hydraulic loads from the service tributary. The source control program in the catchments is the prime priority to secure the lagoon operation. Upgrade options for the IPL system are provided with the capacity enhancement of the existing lagoon, as well as the option to convey the wastewater to NWECC WWTP for treatment.

The recommended upgrades are required to accommodate the regional growth and ensure proper sewage treatment. Therefore, according to the District's Development Cost Charges (DCC) Bylaw 2957 (February 2003), all the upgrades should be eligible for the DCC fund as the costs of expending sewage facility.

4.2 NORM WOOD ENVIRONMENTAL CENTER WASTEWATER TREATMENT PLANT (NWECC)

The short-term (Phase I) upgrade and retrofit options are primarily focused on the operational improvement and system capacity optimization of the existing facility. The long-term (Phase II) upgrade options are planned to extend the treatment capacity for future regional demands. The timely upgrade schedules are highly subject to the population growth scenarios and the degree of treatment required. A 2.5 % of population growth rate is selected for the scheduling. As specified in Section 3.2, Case 1 treatment can achieve carbonaceous BOD removal, nitrification and partial denitrification with air ON/OFF arrangement in the oxidation ditches. Case 2 will achieve carbonaceous BOD removal and nitrification only with full aeration. Case 3 can maintain the lowest level of treatment with carbonaceous BOD removal only. The system capacities at different treatment levels are illustrated in Figure 4.1, translating into the service capacity of population equivalent (PE).

FIGURE 4.1: POPULATION AND TREATMENT CAPACITY PROJECTIONS

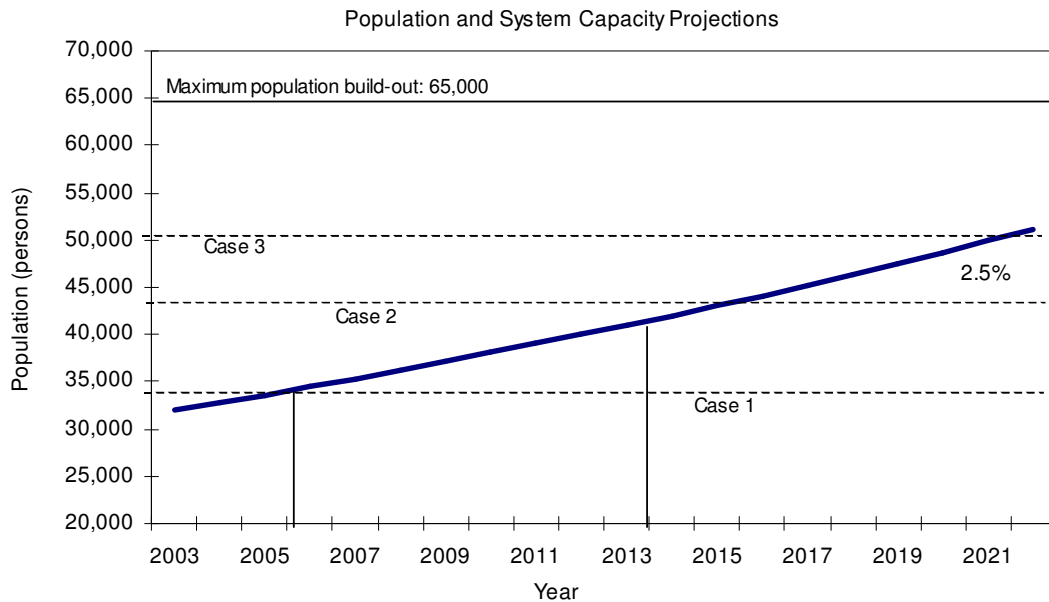

The treatment system capacities at the maximum monthly average flow of each case are 23,000 m³/d, 28,000 m³/d, and 33,000 m³/d, equivalent to 34,000 PE, 44,000 PE and 52,000 PE, respectively. Also, according to the DCR Official Community Planning (OCP, 1997), the maximum infill region build-out populations are estimated to be about 65,000 persons. However, the possibility of conveying the wastewater from the Industrial Park area for treatment is not considered in these projections.

The existing facility will reach the system capacity by the year of 2006 serving 34,000 PE. The limitation of treatment capacity is mainly due to the clarifier capacity limitation. By adding one clarifier (or two to provide redundancy), the service capacity can be extended to about 41,000 PE beyond 2013 (see Figure 4.1). Extra treatment capacity can be further achieved by adjusting the effluent quality to Case 2 or even Case 3 levels, which will extend the service year beyond 2020 approximately.

Two upgrade phases are proposed to accommodate the future demands. The short-term (Phase I) upgrade includes the immediate needs to operate both oxidation ditches and maximize the system capacity by retrofitting the existing unit facilities. Optional improvement and extra secondary clarifier capacity for redundancy are also planned in the short-term upgrade. The long-term (Phase II) is to extend the system capacity to meet the ultimate regional build-out or beyond, by expanding the oxidization ditches, or using other treatment processes.

1. Short-Term (Phase I) Upgrade

This phase of upgrade is in an immediate need for operating both oxidation ditches. This upgrade will ensure the treatment capacity and Case 1 effluent quality from Stage 1a to Stage 1b. The aeration system upgrade is also necessary for optimizing the treatment efficiency and minimizing the chemical (lime) addition in the aerobic digester. The required facility upgrades and retrofits are listed below in order of priority:

Must-Do List

1. Add one additional secondary clarifier and retrofit mixed liquor distribution chamber for even flow distribution
2. Effluent channel and Parshall flume upgrade
3. Add grit removal chamber(s) for the operation of two oxidation ditches in parallel. The headwork building will be expended to house the grit chambers and provide additional space of office/workshop/lunch room. In addition, the screened influent flow split will be improved.

Should-Do List

4. Aeration system upgrade, including (1) air flow distribution and control improvement in the oxidation ditches, (2) blower capacity and control upgrade, and (3) aerobic digester aeration and mixing improvements
5. Other miscellaneous repairs including the gate valve in the sludge withdraw chamber of the aerobic digestion basin, sludge storage basin supernatant recycle pump station, and replacement of in-situ oxidation-reduction potential (ORP) system installation

It is recommended to switch the existing three 150HP Hoffman centrifugal blowers to serve the aerobic digester, and use the existing 250 HP Lamson centrifugal blower and a new 250HP unit for the oxidation ditch operation. Variable frequency drive (VFD) of the blowers is also recommended for better aeration control.

Clarifier capacity expansion is also recommended in this phase of upgrade. By adding one new clarifier (or two clarifiers to provide redundancy), the system treatment capacity can be increased to about 28,000 m³/d of maximum monthly flow (by 2013 at 2.5% growth rate).

An itemized preliminary cost breakdown is detailed in Appendix C and summarized in Table 4.1. The upgrade cost is estimated about \$4,066,000 including the addition of one (1) secondary clarifier, MLSS flow split improvement, two grit chambers, one 250HP centrifugal blowers, influent flow split modification, air flow distribution, blower system retrofit (switch blowers, VFD, piping, and electrical), hydraulic upgrade of the effluent

channel, and mixing in the digester, and headwork building expansion. Item 5 miscellaneous repair is estimated about \$200,000.

For the purposes of maintaining existing effluent quality (i.e. Case 1 Grade A+), expanding the plant capacity, providing more efficient operation, reducing wear & tear on plant infrastructure, and easier facility control, Items 1 to 3 (Must-Do List) are considered the priorities in this Phase I upgrade. The remaining items (Should-Do List) can be deferred if financial constraint applies. Miscellaneous items can be planned in the regular maintenance and repairing expenditures.

TABLE 4.1 COST ESTIMATE OF NVEC WWTP PHASE I UPGRADE

Item	Description	Budgetary Cost
1	Add One Clarifier and Flow Split Modification	\$ 1,587,000
2	Effluent Channel and Parshall Flume Hydraulic Upgrade	\$ 196,000
3	Two Grit Chamber, Headwork Building, Flow Split	\$ 1,315,000
4	Aeration Upgrade	\$ 968,000
Total		\$ 4,066,000

Costs include 7~15% engineering and 25% contingency

2. Long-Term (Phase II) Upgrade

This upgrade involves expanding the system capacity to meet the ultimate regional need (i.e. 65,000 population). This upgrade will ensure the treatment capacity and Case 1 effluent quality from Stage 1b to ultimate build-out. This upgrade may consider adding primary treatment, expanding the oxidization ditch capacity or implementing other treatment options.

- Option 1: Add Primary Clarifiers

Primary clarifiers are recommended to removal 50% of TSS and 30% of BOD influent loads. With these TSS and BOD load reductions, the existing oxidation ditches will still be sufficient to treat the ultimate 65,000 PE ultimate loads at Case 3 effluent quality. A schematic of adding four primary clarifiers is shown in Figure 4.2. A conceptual layout is illustrated in

Appendix A. In this case, the secondary clarifier and solids handling capacity should be expanded accordingly to meet the system demands. The secondary clarifiers should have at least twice of current capacity. The primary sludge can be stabilized with the secondary sludge or a stand-alone primary sludge digester. Additionally, the oxidization ditches can be converted into a modified flow-through plug flow activated sludge with biological nutrient removal (BNR) to enhance the effluent quality (see Figure 4.3).

FIGURE 4.2: SCHEMATIC LAYOUT OF PHASE II OPTION 1 UPGRADE: PRIMARY CLARIFIER

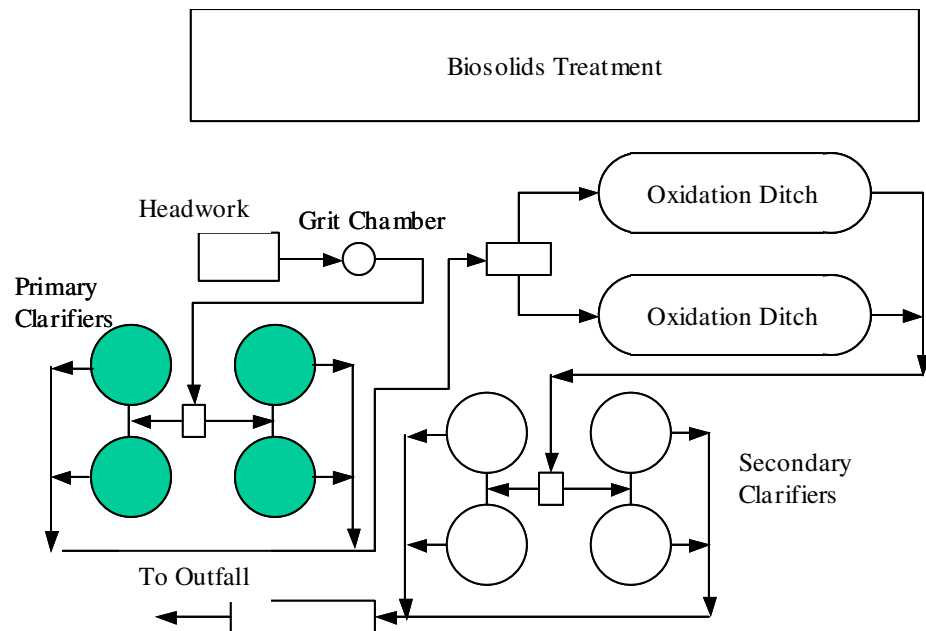
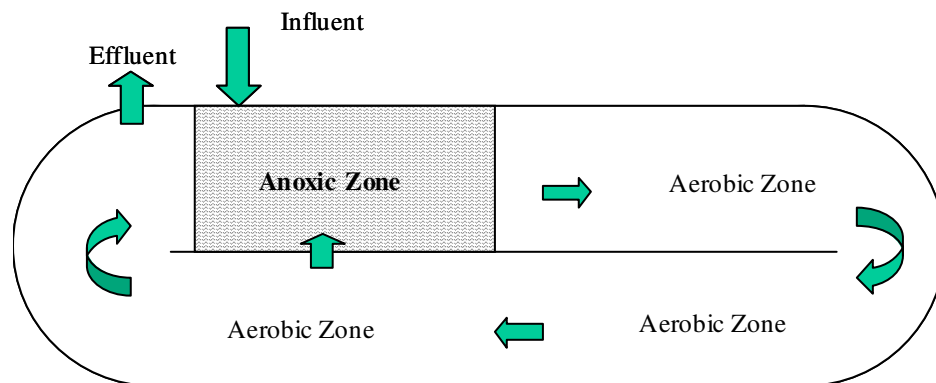

FIGURE 4.3: SCHEMATIC OF OXIDIZATION DITCH MODIFICATION



- Option 2: Add Oxidization Ditches

Additional oxidization ditches are required to accommodate the flow and load increases. A schematic of the oxidization ditches expansion is shown in Figure 4.4. A conceptual layout is illustrated in Appendix B. The secondary clarifier and biosolids handling capacity should be expanded accordingly to meet the system demands. The oxidization ditches can be converted into a modified activated sludge flow-through plug flow with BNR to enhance the level of treatment.

**FIGURE 4.4: SCHEMATIC LAYOUT OF PHASE II OPTION 2 UPGRADE:
OXIDATION DITCHES**

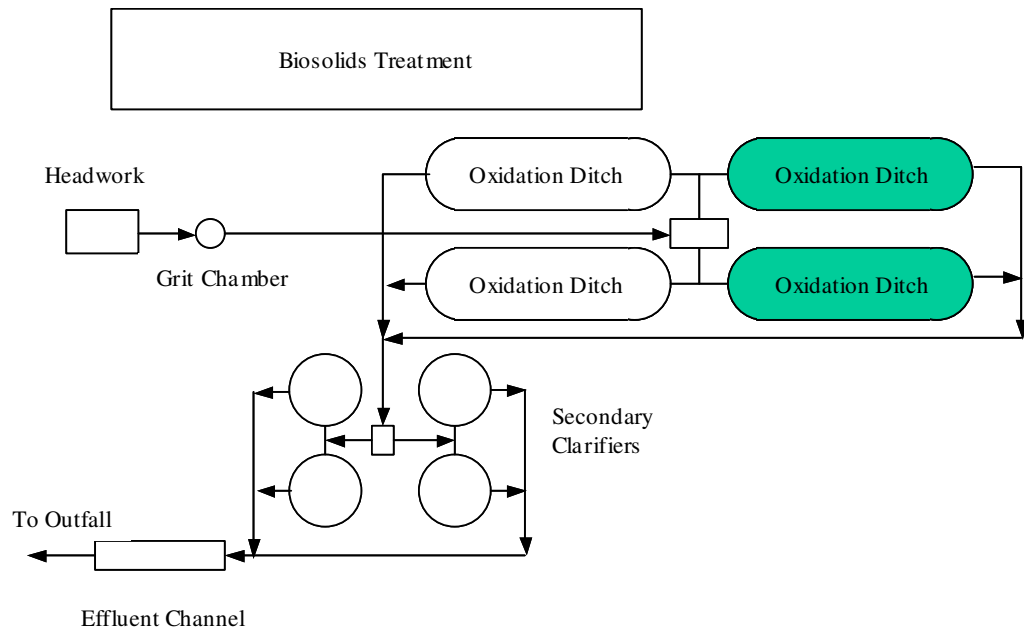

- Option 3: Sequencing Batch Reactor

Alternate treatment process, such as sequencing batch reactor (SBR), can be considered to replace the oxidation ditch process. The SBR is a fill and draw activated sludge system that differs from extended aeration (e.g. current oxidation ditch operation) and conventional activated sludge systems, in that all biological treatment and solids separation processes are completed in one tank without primary or secondary clarifiers (see Figure 4.5 sequence schematics). This treatment system uses a batch process and includes the following phases:

Fill - Influent is fed into the reactor and the liquid level rises

Aeration – The contents of the reactor are mixed and aerated

Settle – Aeration is terminated and a quiescent settling period allows solids to settle leaving a clear effluent in the upper portion of the tank volume

Decant – The clear supernatant is then decanted from the top of the tank

A schematic of the SBR expansion is shown in Figure 4.6. The process sequence is controlled automatically through a PLC with capability of SCADA system integration for operate and maintain. There are no separate clarifiers or sludge recycle streams required. A similar SBR operation in Kent, BC with 5,400 m³/d design capacity, occupies only a 30m by 20 m in footprint. The secondary clarifiers can eventually be decommissioned, and the plant will only handle one type of biosolids.

Because the oxidation ditch process can deliver satisfactory treatment with low O/M cost and not space constraint at the existing site for future expansion (e.g. additional oxidation ditches and clarifiers), this SBR option has been eliminated from further consideration during the Workshop (March 2003).

FIGURE 4.5: A TYPICAL SBR OPERATIONAL STAGES AND SEQUENCES

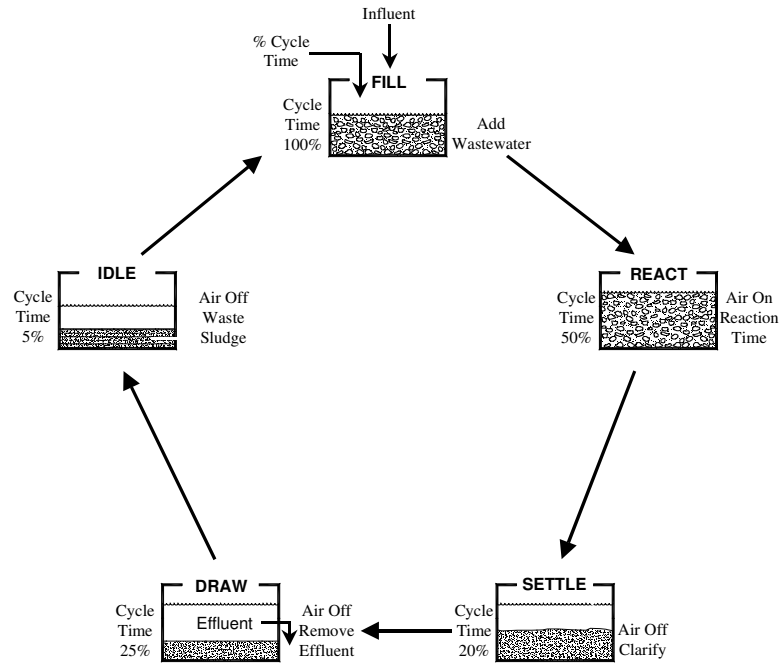
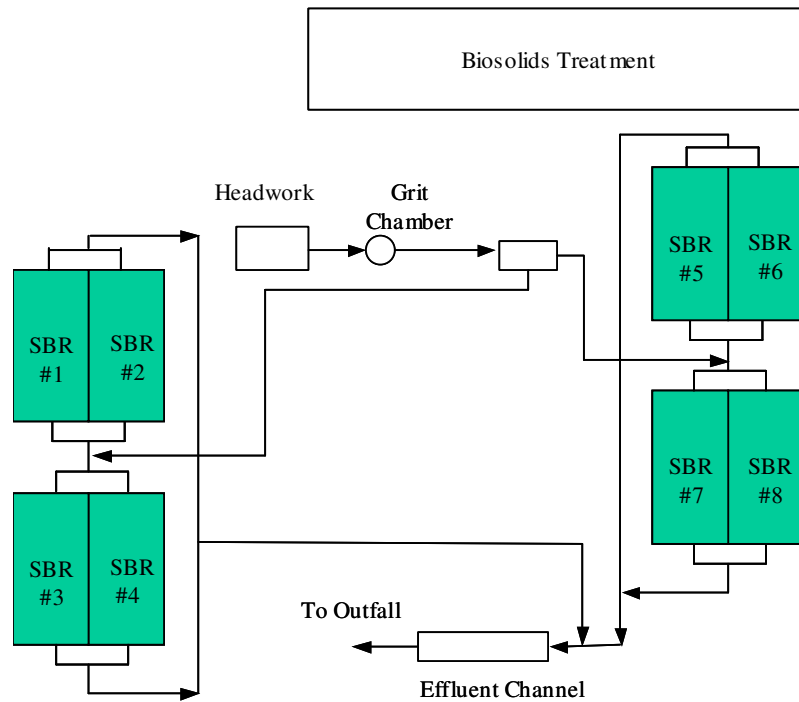

FIGURE 4.6: SCHEMATIC LAYOUT OF PHASE II OPTION 3 UPGRADE: SBR



Aerobic digestion is considered an expensive sludge stabilization process to operate and maintain. This is mainly due to the aeration and mixing requirements. Chemical addition (lime) may become inevitable due to long SRT maintained in the aerobic digestion operation. Anaerobic digestion or composting can be considered as the alternate in this phase of expansion for operational cost savings. Potential energy recovery (heat and methane) can be obtained from the anaerobic digestion and the composting product can be used for beneficial applications. Sludge conditioning including thickening and pH adjustment can be implemented to reduce the capital expense on the anaerobic digester and composting site. Ultimately, the biosolids stabilization option should be considered in accordance with final disposal and reuse plan in place.

At a 2.5% population growth rate scenario, the timelines and estimated costs (cash flows in 2004 dollars) of each upgrade task are summarized in Table 4.2. Items 1 and 3 are based on a preliminary cost estimate discussed in Section 4.2 short-term Phase I upgrade (Must-Do and Should-Do Lists) to achieve Case 1 (Grade A+) effluent quality. Item 2 is recommended to investigate potential inflow/infiltration problems within the sewer catchment and possible mitigation solutions and water conservation initiatives to reduce the sewage flow entering the NVEC WWTP.

Item 4 of the biosolids management planning study is recommended to evaluate the performance of sludge stabilization (i.e. aerobic digestion and lagoon dewatering) and silviculture/plantation application. Subject to market demands and regulatory requirements (BC OMRR), alternative processes such as in-vessel digestion (aerobic or anaerobic), mechanical dewatering, composting, and other land applications, should be reevaluated for future recycle and reuse options.

Items 5 and 6 are estimated to expand additional oxidation ditches and secondary clarifier (Section 4.2 long-term upgrade Option 2) to achieve the same level of treatment as current (Section 3.2.2 Case 1). Items 7, 8, and 9 are required to add primary treatment (four primary clarifiers) and in-vessel sludge digestion (two anaerobic digesters) for treatment capacity expansion.

TABLE 4.2: UPGRADE TIMELINES AND ESTIMATED COST (AT 2.5% GROWTH RATE)

Item	Year	Estimated Costs	Tasks
1	2005	\$200,000	Design Phase I Upgrade
2	2005	\$100,000	I/I Study and Mitigation
3	2006	\$3,800,000	Phase I upgrade in place
4	2008	\$100,000	Biosolids management option planning
5	2010	\$630,000	Design Phase II expansion
6	2014	\$9,000,000	Phase II expansion in place
7	2020	\$770,000	Design new sludge and primary facility
8	2021	\$8,000,000	Construct new sludge facility
9	2022	\$3,000,000	Construct new primary clarifiers

4.3 INDUSTRIAL PARK LAGOON (IPL)

The IPL system has recently experienced high organic and hydraulic loads from the adjacent composting facility and storm surface runoff. Therefore, the source control program in the catchments is the prime priority to secure the lagoon treatment efficiency. The treatment capacity and cost estimates of each upgrade option are provided, including conveying the wastewater to the NVEC WWTP for treatment.

The current level of dry weather flow and load (baseline) IPL is about 50 m³/d and 5 kg/d of BOD, which is about the maximum system capacity under facultative operation mode. The existing lagoon system could not perform satisfactory treatment mainly due to high loads coming from the adjacent composting site and high flow during the storm events. Eliminating these high flow and loads from entering the lagoon system should greatly enhance the system performance.

Future development of the Industrial Park area is subject to many uncertain factors, which increases the difficulty of long term treatment capacity planning. Future expansion of service area including the industrial development and the adjacent residential area will also increase the flow and load substantially. Therefore, rather than forecasting the future growth and demands, the system treatment capacities of different upgrade options are presented. The timely schedule of system upgrade can be determined when the demand reaches the capacities.

Four upgrade options are recommended, including (1) facultative lagoon with hydraulic condition improvement; (2) partial aerated lagoon; (3) constructing a new SBR plant; (4) conveying to the NVEC WWTP for treatment and eventually decommission the lagoon system. In assuring the treatment performance, the

storm flow and high strength process wastewater should be eliminated from entering the system. Alternately, these high strength wastes should be considered in the upgrade decision.

- Option 1: Facultative Lagoon (with hydraulic condition upgrade)

The hydraulic condition upgrade includes the relocation of the south inlet and installation of floating baffle curtains, to improve the resident time in the lagoon. A conceptual layout of this baffle curtain installation is illustrated in Figure 4.7. This upgrade will increase the treatment capacity to 70 m³/d of flow and 10 kg/d of BOD approximately. This is equivalent to about 100 PE in service capacity. The capital cost of this upgrade is estimated to be about \$93,000 (details in Appendix C), plus \$50,000 annual operation/maintenance (O/M) cost (staff, sludge dredging, and monitoring).

- Option 2: Partial aerated Lagoon

In accordance with the hydraulic condition upgrade, the existing lagoon can be further upgraded into a partial aerated system to treat higher organic load. A conceptual layout of this surface aerator installation is illustrated in Figure 4.8. The proposed retrofit will convert 50% of the lagoon volume into aerated operation, which will increase the treatment capacity to 380 m³/d of flow and 70 kg/d of BOD, equivalent to about 600 PE. Increase biomass production and solids deposits are expected due to increased biological reaction and influent loads. Periodical dredging of bottom sludge should be arranged, e.g. twice a year, and it is assumed that the sludge can be removed by pumper truck and stabilized at the NVEC WWTP. The upgrade cost is estimated to be about \$193,000 (the hydraulic upgrade of Option1 excluded, details in Appendix C), plus \$75,000 annual O/M cost.

Base on a review of existing drawings (Stanley Associates Engineering 1982), the IPL outfall capacity is rated at approximately 0.5 cfs, which is capable of handling peak flow of 1,380 m³/d. Using a peak factor of 3.0, the existing outfall is sufficient to handle a flow of 380 m³/d designed in this upgrade.

TABLE 4.7: CONCEPTUAL LAYOUT OF FLOATING BAFFLE CURTAIN INSTALLATION
(IPL UPGRADE OPTION 1)

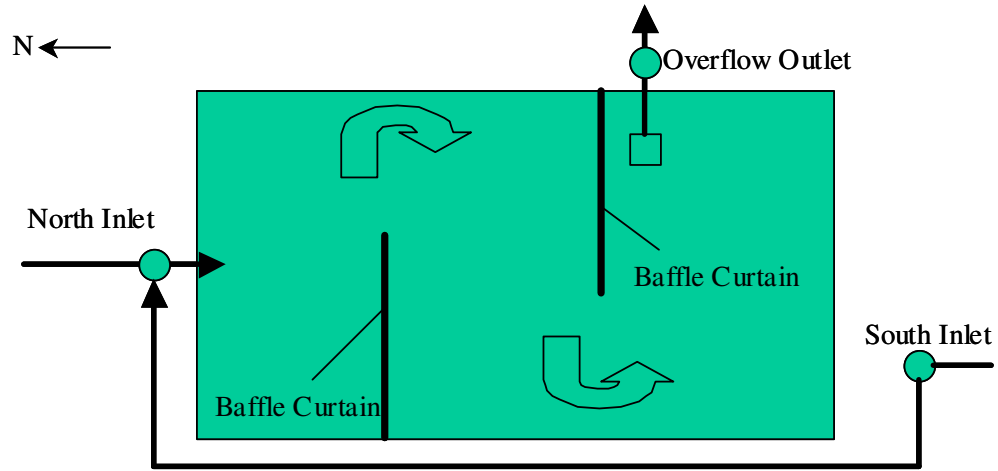
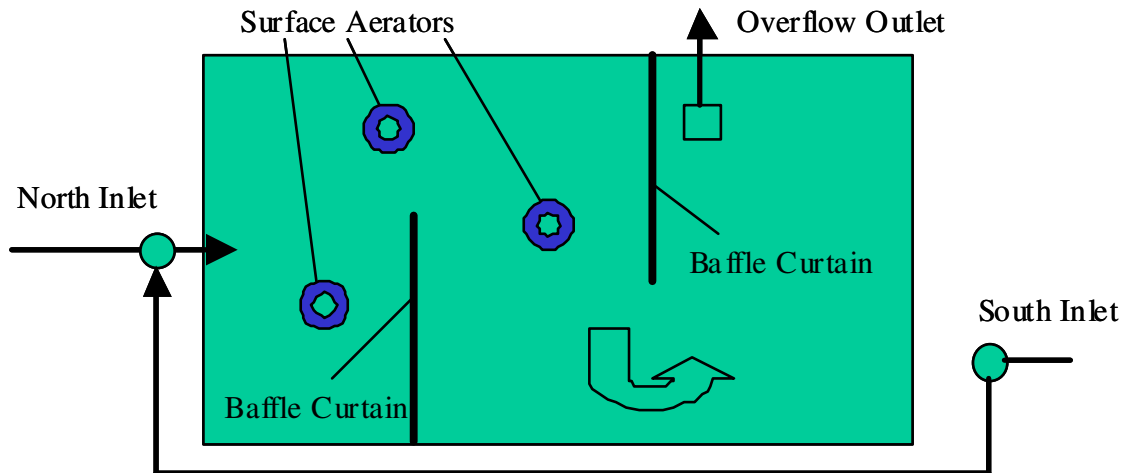

TABLE 4.8: CONCEPTUAL LAYOUT OF AERATOR INSTALLATION (IPL UPGRADE
OPTION 2)



- Option 3: Constructing a new SBR treatment process

A new Sequencing Batch Reactor (SBR) treatment plant can be constructed off-site to provide 800 m³/d of treatment capacity (approximately 1,700 PE) serving the Industrial Park and future development needs (residential and industrial development). The upgrade cost is estimated about \$3,000,000 plus \$200,000 of annual O/M cost (excluding the land purchase). Update of the Liquid Waste Management Plan and operation certificate application is expected to implement this upgrade option (including effluent criteria review and outfall expansion). Outfall capacity expansion is necessary, but is not included in this cost estimate.

- Option 4: Conveying to NVEC for treatment

A 12" diameter gravity sewer system can be constructed to convey the wastewater to the NVEC WWTP for treatment. This upgrading decision should be considered jointly with the NVEC WWTP expansion capacity and future development plan of North Campbell River. Also, the existing PE-6568 permit can be abandoned after the lagoon is decommissioned. The upgrade cost is estimated about \$1,560,000 (details in Appendix C) plus \$50,000 for annual O/M cost (excluding the land purchase and future connecting sewers).

5.0 OPERATIONAL BENCHMARKING

Benchmarking is conducted to evaluate the economic efficiency of plant operation. Three other sewage treatment plants, including the Chemainus STP (District of North Cowichan, BC), and Kent WWTP (Agassiz, BC), and the Peninsula WWTP (Capital Regional District, BC), are compared with the District's Norm Wood Environment Center WWTP. Their treatment processes and design capacities are summarized in Table 5.1.

TABLE 5.1 TREATMENT PLANT PROCESS AND DESIGN CAPACITY

Treatment Plant	Process	Design capacity	Commission year
District of Campbell River, NWEW WWTP	Oxidation ditch and aerobic digester	23,700 m ³ /d	1996
District of North Cowichan, Chemainus STP	Oxidation ditch and aerobic digester	2,000 m ³ /d	1996
District of Kent, Kent WWTP	Sequencing batch reactor (SBR) and aerobic digester	5,400 m ³ /d	1997
Capital Regional District, Peninsula WWTP	Oxidation ditch and alkaline stabilization	36,300 m ³ /d	2000

The operational costs of these four plants are compared in Table 5.2. The operational costs are itemized into labour, power (utility), chemical, maintenance, administration, sludge management, and others, based on their 2001 expenses. The DCR NWEW WWTP has the lowest unit costs among these plants, in terms of per cubic meters sewage treated (~\$0.14/m³) and kilogram of BOD removed (~\$0.92/kg BOD) in the process. NWEW WWTP also achieved comparable effluent quality among these plants. The NWEW WWTP is considered to be a very cost effective operation.

Currently, there are three (3) full-time operators (including one chief operator) responsible for the NWEW WWTP operation (one Level 3 operator just joined the operation in 2004). The operators are also responsible for the Industrial Park Lagoon sampling and analysis. In a comparison of treated sewage per full-time staff ratios (m³/d sewage per full-time staff), the NWEW WWTP (4,734 m³/d/staff) is the highest among the other plants.

**DISTRICT OF CAMPBELL RIVER
LONG TERM SEWAGE TREATMENT STUDY**

TABLE 5.2: OPERATIONAL COST BENCHMARKING

	NWEC WWTP		Chemainus STP		Kent WWTP		CRD WWTP	
Design Flow (m ³ /d)	33000		2000		5400		36300	
Annual Average Flow (m ³ /d)	13255		1108		853		7880	
Average BOD removal (kg/d)	1968		265		196		1900	
Labor	\$169,923	25.8%	\$57,000	35.6%	\$126,076	51.0%	\$392,042	25.8%
Power	\$118,020	17.9%	\$22,000	13.8%	\$30,424	12.3%	\$118,433	7.8%
Chemical	\$24,241	3.7%	\$3,000	1.9%	\$30,000	12.1%	\$77,775	5.1%
Maintenance	\$107,546	16.3%	\$30,000	18.8%	\$20,449	8.3%	\$72,417	4.8%
Sludge Disposal	\$200,000	30.3%	\$24,000	15.0%	\$22,788	9.2%	\$842,721	55.5%
Administration	\$35,971	5.5%	\$20,000	12.5%	\$12,905	5.2%	\$12,698	0.8%
Others	\$3,949	0.6%	\$4,000	2.5%	\$4,440	1.8%	\$3,641	0.2%
Total	\$659,651		\$160,000		\$247,082		\$1,519,727	
Unit Cost (\$/m ³)	\$0.14		\$0.40		\$0.79		\$0.53	
Unit Cost (\$/kg BOD)	\$0.92		\$1.65		\$3.45		\$2.19	
Staff	3*		2**		2.2***		7.6	
(m ³ /d)/Full-Time Staff	4734		739		427		1037	

* Staff also responsible for the Industrial Park Lagoon sampling

** : Staff also responsible for the operation of other two STPs, the Crofton STP (modified activated sludge) and Joint Utilities Board STP (aerated Lagoon)

***: Two full-time and one part-time staff are on duty

6.0 CONCLUSION AND RECOMMENDATIONS

Based on the evaluation work completed in this study, the following conclusions and recommendations are made for both the NWECC WWTP and IPL systems.

6.1 NORM WOOD ENVIRONMENTAL CENTER (NWECC WWTP)

1. The NWECC WWTP is currently receiving sewage load of approximately 31,000 persons, and achieving satisfactory effluent quality in compliance with the permit requirements (BOD and TSS). Certain degree of total nitrogen removal is also achieved in the treatment due to the oxygen and oxidation-reduction potential (DO/ORP) control and aeration scheduling in the oxidation ditch, resulting in low ammonia-N and NO_x-N concentrations in the effluent,
2. In comparisons with three other similar treatment plants, the operational cost benchmarking shows that the NWECC WWTP is operated in a very cost effective way. One additional full-time operator has joined the NWECC WWTP operation to form a team with three full-time staff (including a chief operator).
3. Currently, there is only one oxidation ditch in service alternately, due to low influent load and maintenance needs to remove grit deposit in the ditch. One of the ditch is used for sludge storage in between the silviculture application. Soon, both oxidation ditches need to be operated in parallel to accommodate the influent load increases. Immediate needs to facilitate grit chambers and flow split modification are recommended to assure the operation needs. The arrangement of temporary sludge storage or other alternatives need to be evaluated.
4. Backwater during peak flow was experienced in the secondary clarifiers, resulting in submerge of overflow weir and solids carryover. Possible hydraulic bottlenecks are the clarifier effluent pipes and effluent channel. Further investigation is recommended to evaluate the hydraulic capacity issues.
5. Based on a 2.5% population growth scenario for the next two decades, the regional population will grow to about 52,000 persons by 2023. The treatment capacity of current system is rated about 34,000 PE, with Grade A+ effluent quality. The system capacity is limited by the secondary clarifier capacity.

The treatment system capacity with least degree of treatment (Grade B effluent quality with conventional secondary treatment for BOD and solids removal only) should be sufficient to serve the future demand by the year of 2023. However, the clarifier capacity should be expanded by 2006 to assure the treatment efficiency.

6. Energy and chemical (lime) saving is possible by reducing the aeration time in the oxidation ditches and aerobic digester, which may reduce the nitrification air demand and increase the degree of denitrification. By providing proper mechanical mixing and aeration control in the aerobic digester, the air requirement can be reduced and the degree of nitrification and alkalinity demand can be minimized.
7. The capacity of existing secondary clarifier is identified as the system bottleneck due to the hydraulic and solids loads. The upgrade of clarifier capacity is necessary to maximize the system treatment capacity.

Recommendations

1. The impact of inflow and infiltration (I/I) is apparent in the NVEC WWTP service tributary, however, there is not sufficient information to justify its degree quantitatively during this study.

A comprehensive I/I study is recommended to investigate the degree of I/I contribution within the sewer tributary. The results of I/I study may change the decision of major infrastructure upgrades. The demand of sewer collection, pump stations, and treatment plant capacity can be reduced and possibly be deferred by effective I/I mitigation measures.

A complete I/I study should be able to quantify the I/I problem, identify the I/I sources, and evaluate the cost-effective correction plan. Sewer rehabilitation program can be developed and evaluated, in conjunction with the upgrade plans of sewer collection system and treatment plant to justify and prioritize the infrastructure investments.

Other source control program can be considered to reduce the sewer inflow, such as low-flush toilet requirement in new construction and renovation applications.

2. This short-term (Phase I) upgrade will ensure the treatment capacity to serve approximately 28,000 m³/d (41,000 PE), representing the maximum monthly flow for 2013, at a 2.5% population growth scenario and Grade A+ effluent quality. By changing the operational conditions and reducing the effluent quality objective (e.g. Grade A and B), the treatment capacity can be expended beyond 2023 (52,000 PE). The recommended upgrade and retrofit for the NVEC WWTP system include the followings in order of priority:

Must-Do List

- 1). Add one additional secondary clarifier and retrofit mixed liquor distribution chamber for better flow distribution.
- 2). Effluent channel and Parshall flume upgrade.

- 3). Add grit removal chamber(s) for the operation of two oxidation ditches in parallel. Screened influent flow split improvement with splitter boxes and flow monitoring will be incorporated.

Should-Do List

- 4). Aeration system upgrade, including
 - Oxidation Ditches
Improvement of airflow distribution and control with modular valves and DO/ORP monitoring.
 - Blower
Switch the existing three 150HP Hoffman centrifugal blowers for the aerobic digester, and use the existing 250 HP Lamson centrifugal blower plus a new 250HP unit for the oxidation ditch operation. Variable frequency drive (VFD) of the blowers is also recommended for efficient aeration control.
 - Aerobic digester
Provide mechanical type of mixers for the aerobic digester mixing and aeration control improvement in conjunction with blower upgrade.
- 5). Other miscellaneous repairs including the gate valve in the sludge withdraw chamber of the aerobic digestion basin, sludge storage basin supernatant recycle pump station, and replacement of in-situ oxidation-reduction potential (ORP) system installation

If financial constraint applies, these upgrades can be staged in based on the priority described in Section 4.2.

A detailed engineering study/audit is recommended to evaluate the engineering options and cost/benefit of the upgrades identified above. The study/audit should evaluate the feasible

3. The long-term (Phase II) upgrade of the NVEC requires the expansion of the treatment capacity beyond the design Stage 1b to meet the ultimate regional build-out need, e.g. 65,000 persons and beyond. The upgrade options include the following, with the provision of short-term (Phase I) upgrade in place:
 - Add oxidation ditches and secondary clarifiers
 - Add primary clarifiers and sludge handling capacity (sludge stabilization and dewatering)

By changing the operational conditions and reducing the effluent quality objectives, the treatment capacity can be further expanded. However, such decision should be carefully reviewed. Ratification with Environmental authority is required, such as ammonia-N concentration and effluent toxicity.

Besides, the long-term upgrade decision should consider the possibility to provide service for the Industrial Park area as well.

4. Biosolids stabilization options should be further investigated, including the anaerobic digestion and composting, with the provision of sludge conditioning prior to the treatment (i.e. thickening, pH adjustment etc.). The treatment option is also subject to the final reuse and recycle options, to meet the BC Organic Matter Recycling Regulation (BC OMRR) requirements, (e.g. Class A or Class B biosolids).
5. Long-term sewage treatment upgrade strategies are recommended as follows to provide sewage treatment service for the region:
 - 1). Continue the source control and Inflow/infiltration (I/I) mitigation program in the tributary to reduce the sewage treatment capacity demands
 - 2). Complete the Phase I upgrade to maximize the treatment capacity of existing infrastructure. Implementing the Phase II upgrade by adding oxidation ditches, secondary clarifiers, and sludge handling facilities to expand the overall treatment capacity.
 - 3). Add primary clarifiers to expand the treatment capacity and convert the oxidation ditches into a flow through biological nutrient removal (BNR) mode for effluent quality enhancement in the future.
 - 4). Connect the Industrial Park area and other sewer systems to the NVEC WWTP for treatment. This upgrade will eventually result in the catchment boundary expansion. Eventually the District will have the NVEC WWTP as the central treatment system to serve the entire sewer tributary.
 - 5). Continue to review the biosolids management needs for future market demands and regulatory requirements. Biosolids handling option should be considered in accordance with the District's Long-Term Biosolids Management Plan for the final reuse and disposal.

6.2 INDUSTRIAL PARK LAGOON (IPL)

1. Recent flows and loads entering the Industrial Park Lagoon have exceeded the system capacity. These excessive flows and loads were mainly contributed by the stormwater, fish processing and composting operations, and most likely were the causes of frequent effluent quality violations. The discharge of composting leachate effluent into the lagoon system has been discontinued.

DCR is continuing the effluent monitoring, and the latest effluent results are now in compliance with the permit. Source control and monitoring program should be continued and expanded.

2. The impact of stormwater and surface runoff should be further investigated, including the sewer connection and catchments area, to reduce excessive I&I flows (e.g. smoke testing).
3. The existing facultative lagoon system is capable of treating the wastewater generated from the Industrial Park with minor hydraulic condition upgrade. The system capacity is rated about 70 m³/d, 10 kg/d BOD, and 10 kg/d TSS, which is equivalent to approximately 100 PE.
4. The lagoon treatment capacity can be enhanced by the hydraulic condition improvement and partial aeration. This upgrade should be triggered by the plan to serve more than 100 PE within the IPL catchment. However, the ultimate capacity can only be upgraded to about 600 PE (380 m³/d) with aeration.
5. The existing outfall capacity is rated at approximately 0.5 cfs, which is capable of handling peak flow of 1,380 m³/d. Using a peak factor of 3.0, the existing outfall is sufficient to handle a flow of 70 m³/d for facultative operation and 380 m³/d designed for the partial aerated lagoon operation.

Recommendations

1. The source control program should be continued to protect the lagoon operation.
2. A rational long-term alternate to provide sewage treatment service in the region is to convey the wastewater to the NVEC WWTP for treatment. This option will eventually decommission the IPL operation and integrate the regional sewage treatment in one location (i.e. NVEC WWTP). This option involves the construction of a gravity sewer system along the Island Highway and associated maintenance. The loading impact from the IPL source, including the residential area, future industrial development and expansion of sewer service boundary (e.g. North Campbell River), should be evaluated in conjunction with the further NVEC WWTP upgrade planning.

7.0 REFERENCE

Stanley Associates Engineering 1982, Industrial Park Sewage Disposal System, As-Build Drawings.

USEPA 1983, Design Manual, Municipal Wastewater Stabilization Ponds.

Dayton & Knight Ltd 1991, District of Campbell River Liquid Waste Management Plan Stage II.

Frederick, G. L. and Lloyd, B. J. 1996, An evaluation of retention time and short-circuiting in waste stabilization ponds using *Serratia Marcescens* bacteriophage as a tracer, Water Science and Technology, v33, n7, p49-56.

Ten State Standards 1997, Recommended Standards for Wastewater facilities, Health Education Services.

District of Campbell River 1997, District of Campbell River Official Community Planning (OCP).

Dayton & Knight Ltd 1997, Norm Wood Environmental Center Secondary Facility and Operating Building, As-Build Drawings.

Dayton & Knight Ltd 2000, Norm Wood Environmental Center Operation & Maintenance Manual.

Highland Engineering/Ludvigson Land Surveying 2002, Campbell River Industrial Park Sewage Treatment System.

APPENDICES

APPENDIX A: CONCEPTUAL LAYOUT OF NVEC WWTP PHASE II OPTION 1

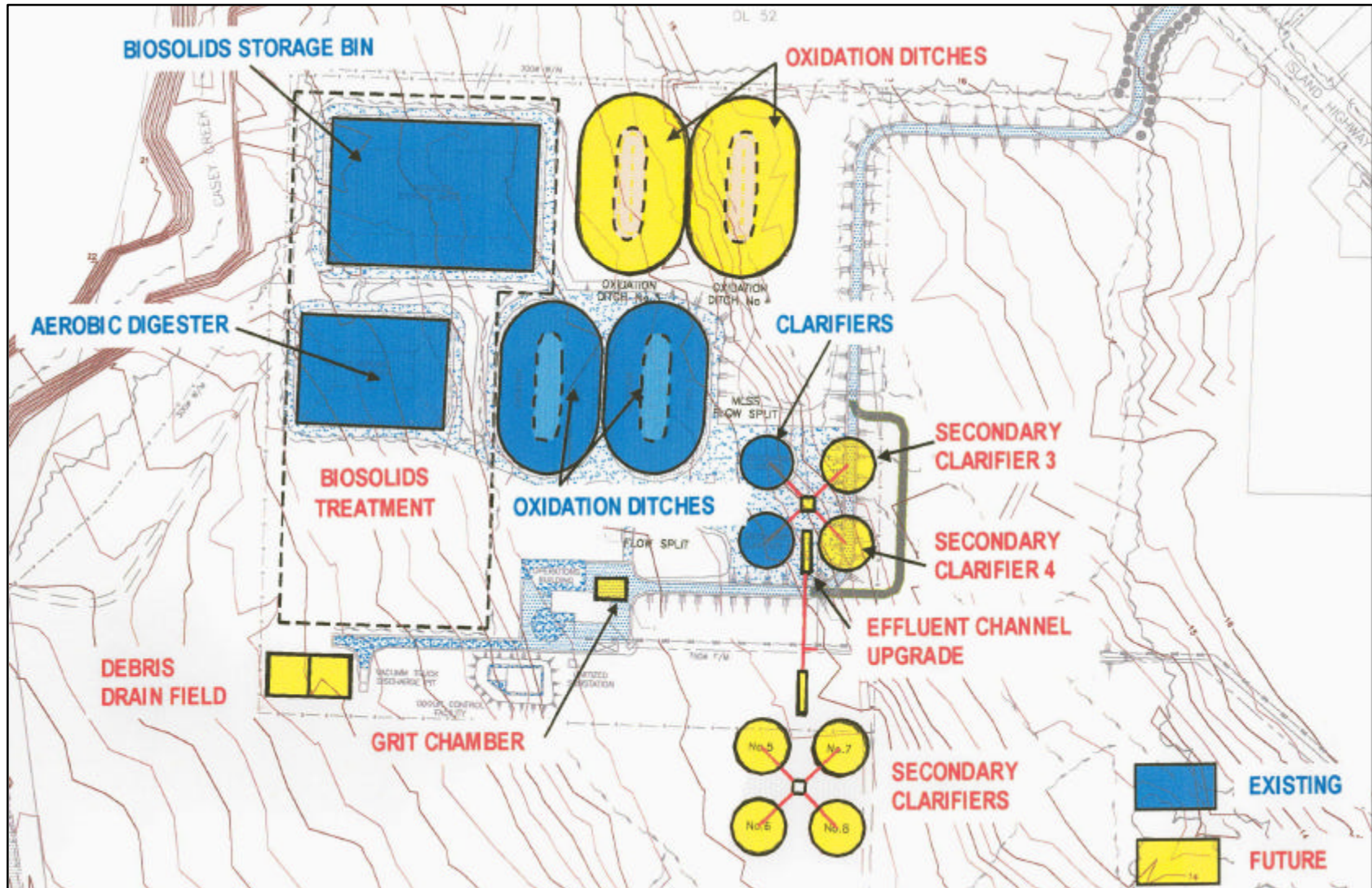

APPENDIX B: CONCEPTUAL LAYOUT OF NVEC WWTP PHASE II OPTION 2

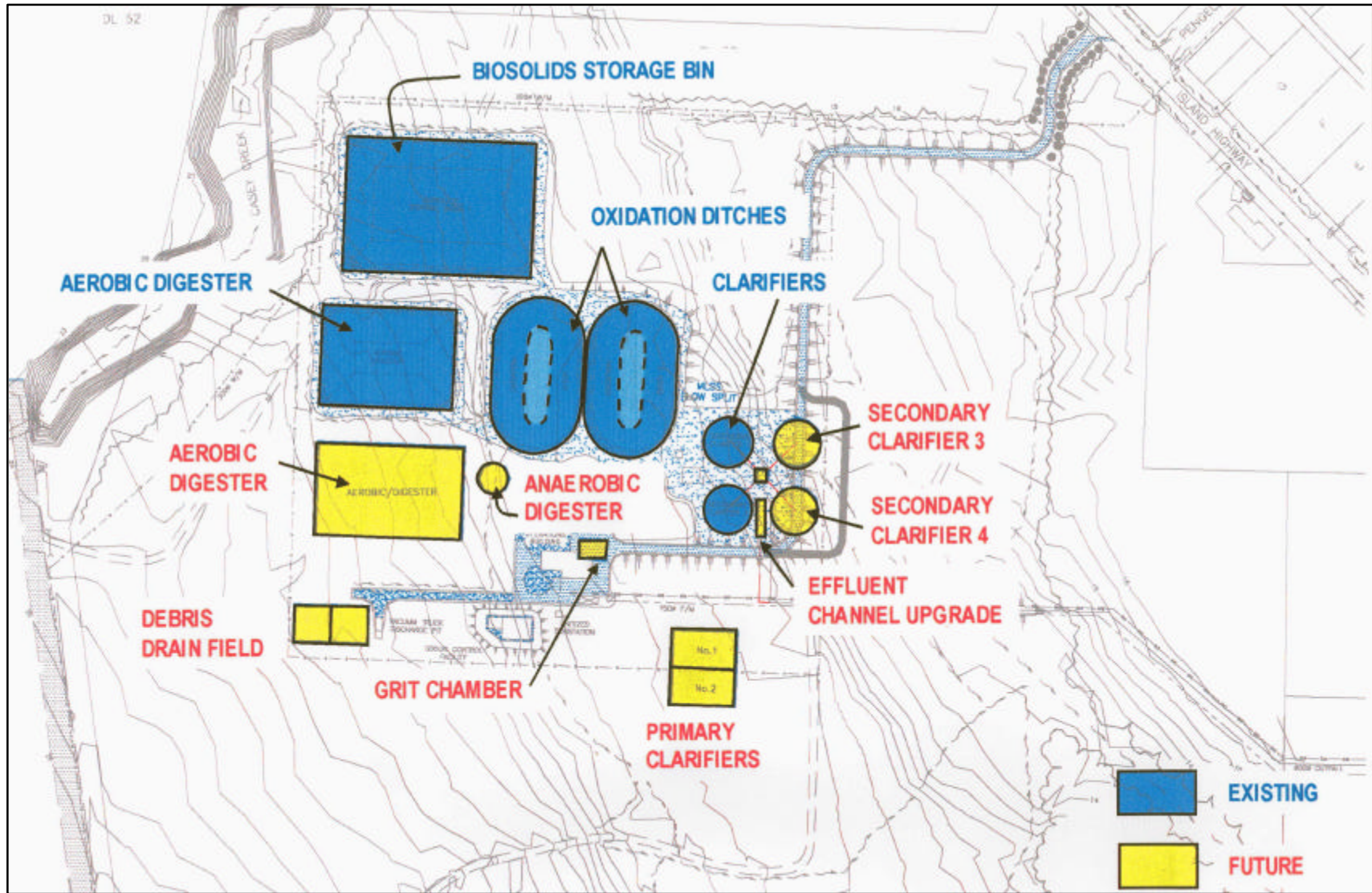

**DISTRICT OF CAMPBELL RIVER
LONG TERM SEWAGE TREATMENT STUDY**

APPENDIX C: COST ESTIMATES

District of Campbell River NWECC WWTP
Phase I (Short-Term) Upgrade
Infrastructure Upgrade - Item 1

Add one secondary clarifier
Retrofit mixed liquor distribution chamber/piping

2004 Dollars

Cost Estimate

No.	Item	Description	Quantity	Unit	Price/Unit	Material	Labour	Amount
1	General Requirement		1	l.s.	\$50,000			\$50,000
						Total for General Requirement		\$50,000
2	Site Work							
	2.1 Excavation and Backfill							
		Excavation	2000	m3	\$10		Included	\$20,000
		Backfill	400	m3	\$10		Included	\$4,000
	2.2 Dewatering							
		Dewatering allowance	1	l.s.	\$25,000		Included	\$25,000
						Total for Site Work		\$49,000
3	Flow Split Modification							
		MLSS distribution chamber	1	l.s.	\$150,000		Included	\$150,000
						Total for Flow Split Modification		\$150,000
4	Clarifier							
		one (1) 27m diameter clarifier	1	l.s.	\$180,000	\$180,000	\$50,000	\$230,000
		Concrete tank	750	m3	\$600		Included	\$450,000
		Pumps	1	l.s.	\$60,000		Included	\$60,000
		Valve/piping	1	l.s.	\$120,000		Included	\$120,000
						Total for Clarifier		\$860,000
5	Electrical and Instrumentation							
		Controls and instrumentation	1	l.s.	\$80,000		Included	\$80,000
		General electrical	1	l.s.	\$10,000		Included	\$10,000
		BC Hydro service	1	l.s.	\$3,000		Included	\$3,000
						Total for Electrical and Instrumentation		\$93,000

Sub-Total = \$1,202,000

Engineering @ 7% = \$84,140

Contingency @ 25% = \$300,500

Total Preliminary Estimate = \$1,586,640

**DISTRICT OF CAMPBELL RIVER
LONG TERM SEWAGE TREATMENT STUDY**

District of Campbell River NWECC WWTP
Phase I (Short-Term) Upgrade
Infrastructure Upgrade - Item 2

Effluent channel upgrade
Parshall flume upgrade

2004 Dollars

Cost Estimate

No.	Item	Description	Quantity	Unit	Price/Unit	Material	Labour	Amount
1	General Requirement		1	l.s.	\$15,000			\$15,000
						Total for General Requirement		\$15,000
2	Site Work							
	2.1 Excavation and Backfill							
		Excavation	400	m3	\$10		Included	\$4,000
		Backfill	100	m3	\$10		Included	\$1,000
	2.2 Dewatering							
		Dewatering allowance	1	l.s.	\$5,000		Included	\$5,000
						Total for Site Work		\$10,000
3	Effluent Hydraulic Upgrade							
		500 mm PVC pipe	60	m	\$300		Included	\$18,000
		Parshall flume	1	l.s.	\$10,000		Included	\$10,000
		Concrete tank	140	m3	\$600		Included	\$84,000
						Total for Effluent Upgrade		\$112,000
4	Electrical and Instrumentation							
		Controls and instrumentation	0	l.s.	\$0		Included	\$0
		General electrical	1	l.s.	\$3,000		Included	\$3,000
		BC Hydro service	0	l.s.	\$0		Included	\$0
						Total for Electrical and Instrumentation		\$3,000

Sub-Total = \$140,000

Engineering @ 15% = \$21,000

Contingency @ 25% = \$35,000

=

Total Preliminary Estimate = \$196,000

**DISTRICT OF CAMPBELL RIVER
LONG TERM SEWAGE TREATMENT STUDY**

District of Campbell River NWECC WWTP
Phase I (Short-Term) Upgrade
Infrastructure Upgrade - Item 3

Two grit chamber
Screened influent flow split
Headworks building expansion

2004 Dollars

Cost Estimate

No.	Item	Description	Quantity	Unit	Price/Unit	Material	Labour	Amount
1	General Requirement		1	l.s.	\$60,000			\$60,000
						Total for General Requirement		\$60,000
2	Site Work							
	2.1 Excavation and Backfill							
		Excavation	400	m3	\$10		Included	\$4,000
		Backfill	100	m3	\$10		Included	\$1,000
	2.2 Dewatering							
		Dewatering allowance	1	l.s.	\$25,000		Included	\$25,000
						Total for Site Work		\$30,000
3	Headworks Building Expansion							
		Headwork building	300	m2	\$700		Included	\$210,000
		Concrete	250	m3	\$600		Included	\$150,000
		HVAC and plumbing	1	l.s.	\$100,000		Included	\$100,000
		Hand stop gate	6	each	\$5,000	\$30,000	\$5,000	\$35,000
						Total for Headworks Building		\$495,000
4	Grit Chambers							
		Two 10' grit chambers	2	each	\$90,000	\$180,000	\$20,000	\$200,000
		Grit washer	1	each	\$12,000	\$12,000	Included	\$12,000
						Total for Grit Chamber		\$212,000
5	Flow Split Modification							
		Influent chamber piping	1	l.s.	\$100,000		Included	\$100,000
						Total for Flow Split Modification		\$100,000
6	Electrical and Instrumentation							
		Controls and instrumentation	1	l.s.	\$55,000		Included	\$55,000
		General electrical	1	l.s.	\$10,000		Included	\$10,000
		BC Hydro service	1	l.s.	\$12,000		Included	\$12,000
						Total for Electrical and Instrumentation		\$77,000

Sub-Total = \$974,000

Engineering @ 10% = \$97,400

Contingency @ 25% = \$243,500

Total Preliminary Estimate = \$1,314,900

**DISTRICT OF CAMPBELL RIVER
LONG TERM SEWAGE TREATMENT STUDY**

District of Campbell River NWECC WWTP
Phase I (Short-Term) Upgrade
Infrastructure Upgrade - Item 4

Aeration System Upgrade

2004 Dollars

Cost Estimate

No.	Item	Description	Quantity	Unit	Price/Unit	Material	Labour	Amount
1	General Requirement		1	l.s.	\$50,000			\$50,000
						Total for General Requirement		\$50,000
6	Aeration Piping and Control Retrofit							
		Blower room piping modification	1	l.s.	\$100,000		Included	\$100,000
		Aeration system modification	1	l.s.	\$60,000		Included	\$60,000
		VFD for blowers	1	l.s.	\$190,000	\$190,000	\$10,000	\$200,000
						Total for Aeration Retrofit		\$360,000
9	Aerobic Digester Mixing							
		Surface mixer	3	each	\$10,000	\$30,000	\$10,000	\$40,000
						Total for Mixing System		\$40,000
10	Blower							
		Centrifugal blower (250HP)	1	each	\$75,000	\$75,000	\$12,000	\$87,000
		Piping and valve	1	l.s.	\$120,000		Included	\$120,000
						Total for Blower		\$207,000
11	Electrical and Instrumentation							
		Controls and instrumentation	1	l.s.	\$60,000		Included	\$60,000
		General electrical	1	l.s.	\$10,000		Included	\$10,000
		BC Hydro service	1	l.s.	\$6,000		Included	\$6,000
						Total for Electrical and Instrumentation		\$76,000

Sub-Total = \$733,000

Engineering @ 7% = \$51,310

Contingency @ 25% = \$183,250

Total Preliminary Estimate = \$967,560

**DISTRICT OF CAMPBELL RIVER
LONG TERM SEWAGE TREATMENT STUDY**

District of Campbell River IPL Upgrade Option 1
Infrastructure upgrade
Cost Estimate

Hydraulic Upgrade

2004 Dollars

No.	Item	Description	Quantity	Unit	Price/Unit	Material	Labour	Sub-total
1	General Requirement		1	l.s.	\$10,000			\$10,000
						Total for General Requirement		\$10,000
2	Site Work							
	2.1 Excavation and Backfill							
		Excavation	70	m3	\$10	\$700	Included	\$700
		Backfill	60	m3	\$10	\$600	Included	\$600
	2.2 Underground Piping							
		150 mm PVC pipe	120	m	\$160	\$19,200	\$10,000	\$29,200
		manhole	1	set	\$5,000	\$5,000	\$4,000	\$9,000
						Total for Site Work		\$39,500
4	Baffle Curtain							
		Polypropylene Baffle Curtain (36mil)	60	m	\$110	\$6,600	\$8,000	\$14,600
						Total for Baffle Curtain		\$14,600
6	Other Costs							
						Total for Other Costs		\$0

Sub-Total = \$64,100

Engineering @ 15% = \$9,615

Contingency @ 30% = \$19,230

Total Preliminary Estimate = \$92,945

**DISTRICT OF CAMPBELL RIVER
LONG TERM SEWAGE TREATMENT STUDY**

District of Campbell River IPL Upgrade Option 2
Infrastructure upgrade
Cost Estimate

Hydraulic Upgrade and Aeration

2004 Dollars

No.	Item	Description	Quantity	Unit	Price/Unit	Material	Labour	Sub-total
1	General Requirement		1	l.s.	\$10,000			\$10,000
						Total for General Requirement		\$10,000
2	Site Work							
	2.1 Excavation and Backfill							
		Excavation	65	m3	\$10	\$650	Included	\$650
		Backfill	60	m3	\$10	\$600	Included	\$600
	2.2 Underground Piping							
		150 mm PVC pipe	120	m	\$160	\$19,200	\$10,000	\$29,200
		manhole	1	set	\$5,000	\$5,000	\$4,000	\$9,000
						Total for Site Work		\$39,450
3	Aeration System							
		Surface aerators	3	each	\$11,000	\$33,000	\$15,000	\$48,000
						Total for Aeration System		\$48,000
4	Baffle Curtain (included in Option 1)							
		Polypropylene baffle curtain (36mil)	0	m	\$110	\$0	\$0	\$0
						Total for Baffle Curtain		\$0
5	Electrical and Instrumentation							
		Controls and Instrumentation	1	l.s.	\$15,000			\$15,000
		General Electrical	1	l.s.	\$15,000			\$15,000
		BC Hydro Service	1	l.s.	\$10,000			\$10,000
						Total for Electrical and Instrumentation		\$40,000
6	Other Costs							
						Total for Other Costs		\$0

Sub-Total = \$137,450

Engineering @ 15% = \$20,618

Contingency @ 25% = \$34,363

Total Preliminary Estimate = \$192,430

**DISTRICT OF CAMPBELL RIVER
LONG TERM SEWAGE TREATMENT STUDY**

**District of Campbell River IPL I Upgrade Option 4
Infrastructure upgrade
Cost Estimate**

2004 Dollars

No.	Item	Description	Quantity	Unit	Price/Unit	Material	Labour	Amount
1	General Requirement		1	I.s.	\$80,000			\$80,000
						Total for General Requirement		\$80,000
2	Site Work							
	2.1 Excavation and Backfill							
		Excavation	2000	m3	\$10		Included	\$20,000
		Backfill	1850	m3	\$10		Included	\$18,500
	2.2 Underground Piping							
		200 mm Cast Iron Pipe	3500	m	\$180		Included	\$630,000
		Manhole	35	each	\$5,500		Included	\$192,500
						Total for Site Works		\$861,000
3	Headbox							
		Concrete	10	m3	\$800		Included	\$8,000
		Motorized Valve Control	1	I.s.	\$12,000	\$12,000	\$8,000	\$20,000
						Total for Headbox		\$28,000
4	Electrical and Instrumentation							
		Level Sensor	1	I.s.	\$3,000	\$3,000	Included	\$3,000
		Flow meter	1	I.s.	\$6,000	\$6,000	Included	\$6,000
		Controls and Instrumentation	1	I.s.	\$10,000			\$10,000
		General Electrical	1	I.s.	\$20,000			\$20,000
		BC Hydro Service	1	I.s.	\$10,000			\$10,000
						Total for Electrical and Instrumentation		\$49,000
5	Other Costs							
		Backfill of Lagoon	6200	m3	\$15			\$93,000
						Total for Other Costs		\$93,000

Sub-Total = \$1,111,000

Engineering @ 15% \$166,650

Contingency @ 25% = \$277,750

Total Preliminary Estimate = \$1,555,400

**APPENDIX D NORM WOOD ENVIRONMENTAL CENTER SEWAGE
TREATMENT PLANT CATCHMENT AREA**

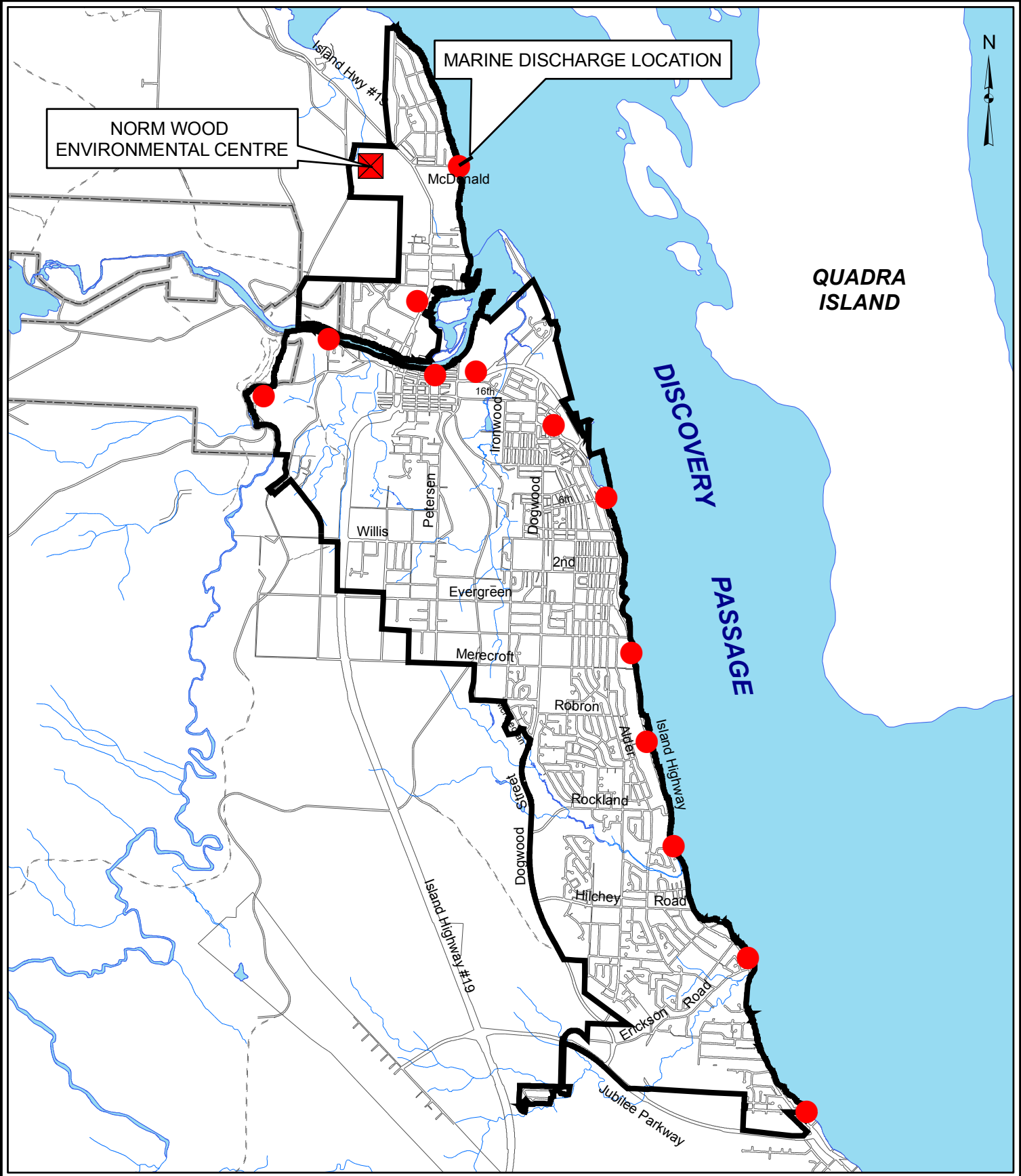



MARINE DISCHARGE LOCATION

NORM WOOD ENVIRONMENTAL CENTRE

QUADRA ISLAND

DISCOVERY PASSAGE

This map indicates subdivision relationship only and should not be used to establish legal lot size or dimensions. This map has been produced using data from a variety of sources and may not be complete or accurate. The District of Campbell River is not responsible for any errors or omissions.
 Date: September 27, 2004
 Scale: 1:65,000
 Projection: UTM Zone 10
 Datum: NAD 83

 Pump Station
 Catchment Boundary



DISTRICT OF CAMPBELL RIVER
 ENGINEERING SERVICES DEPARTMENT

NORM WOOD ENVIRONMENTAL CENTRE
 SEWAGE TREATMENT PLANT
 CATCHMENT AREA

APPENDIX E INDUSTRIAL PARK LAGOON SEWER CATCHMENT AREA

MIDDLE POINT



DISCOVERY
PASSAGE

TERMINAL PL.

BARGE TERMINAL RD.

MARINE DISCHARGE LOCATION

LAGOON

DUNCAN BAY ROAD

MENZIES WAY

MIDDLE POINT DRIVE

MIDPORT ROAD

ISLAND HIGHWAY 19

This map indicates subdivision relationship only and should not be used to establish legal lot size or dimensions. This map has been produced using data from a variety of sources and may not be complete or accurate. The District of Campbell River is not responsible for any errors or omissions.

Date: September 27, 2004
 Scale: 1:10,000
 Projection: UTM Zone 10
 Datum: NAD 83

 Catchment Boundary



DISTRICT OF CAMPBELL RIVER
 ENGINEERING SERVICES DEPARTMENT

INDUSTRIAL PARK SEWAGE LAGOON
 CATCHMENT AREA